

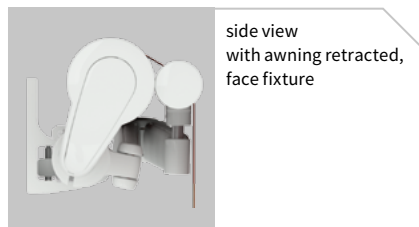

markilux 1700

Striking design, proven technology –
the elegant and stylish open awning





side view with awning retracted, face fixture

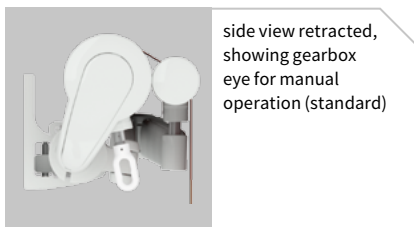

side view retracted, showing gearbox eye for manual operation (standard)

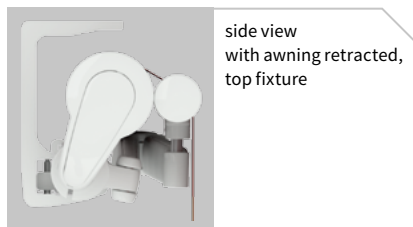

side view with awning retracted, top fixture

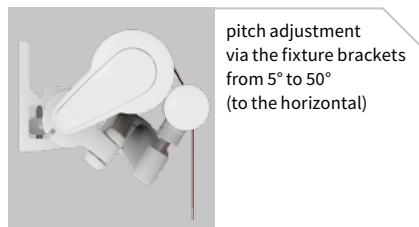

pitch adjustment via the fixture brackets from 5° to 50° (to the horizontal)

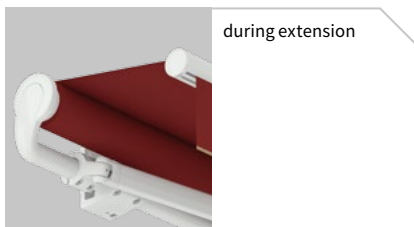

during extension



folding arms with bionic tendon (standard)

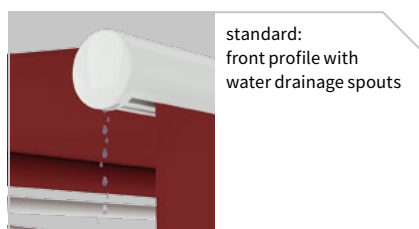

standard: front profile with water drainage spouts



optionally available with system coverboard, as well as markilux flexlight lighting (please refer to the section "Optional Accessories")

Design Features

the design has received numerous accolades:

- reddot Design Award: winner
- German Design Award: nominee

the classic shape of an open patio awning with a stylish new look

the transition from torque bar to roller tube is curved and homogeneous

the side caps available in polished chrome offer an optional designer touch

Technical Specification

attractive front profile made of extruded aluminium with integrated gutter and water drainage spouts

sturdy, round steel torque bar, 50 mm Ø, to prevent twist and deflection

the 85 mm roller tube ensures the highest stiffness and the best possible cover winding characteristics even at the largest widths

the extremely sturdy awning construction makes it possible to shade even very large areas safely

unique arm technology with power transference using bionic tendon made of high-tech fibres with extremely high tensile strength. Tested by The Fraunhofer Institute

Optional Accessories

hard-wired motor operation (optionally with automatic weather controls) for straightforward and easy operation

radio-controlled motor with handheld remote control for ease of use

in the case of manual operation ease of use is ensured with the spring-assisted gearbox

available with the transparent system coverboard

awning available in non-standard RAL colours

Lounge colours / Combinations

markilux 1700

traffic white

RAL 9016

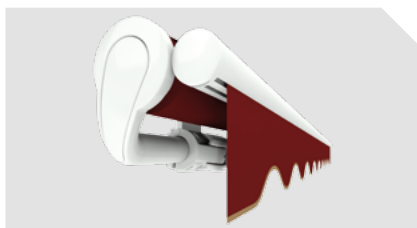

End caps in polished chrome

traffic white

RAL 9016

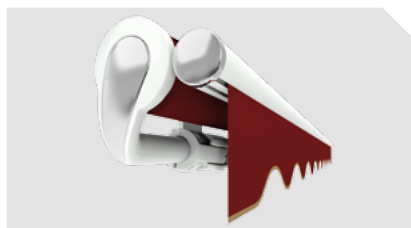

metallic aluminium

RAL 9006

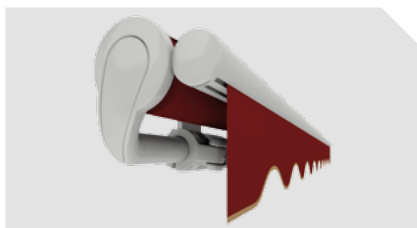

metallic aluminium

RAL 9006

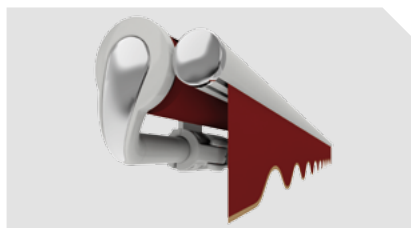

off-white textured finish 5233

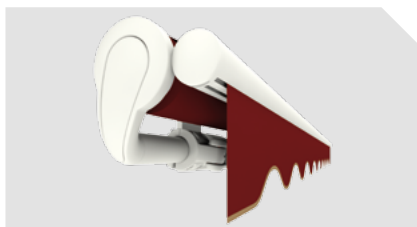

off-white textured finish 5233

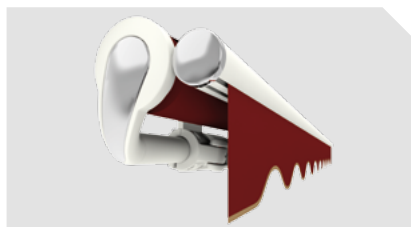

stone grey metallic 5215

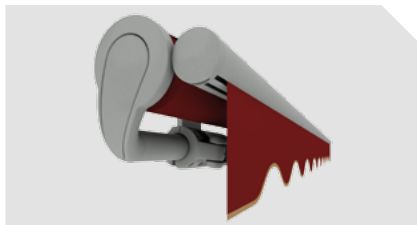

stone grey metallic 5215

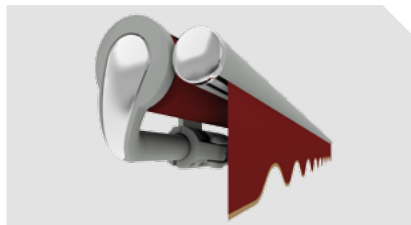

anthracite metallic 5204

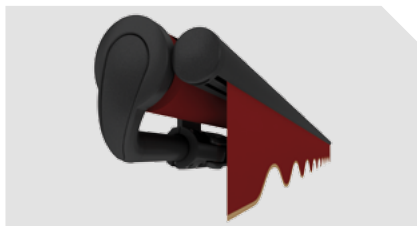

anthracite metallic 5204

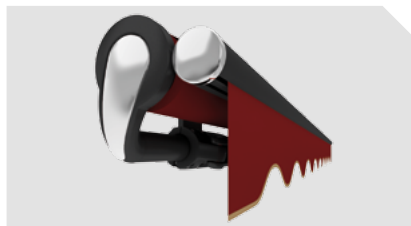

Havana brown textured finish* 5229

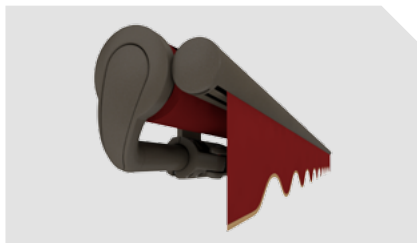

Havana brown textured finish* 5229

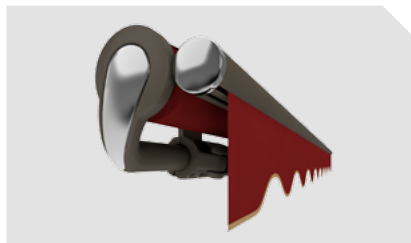







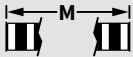
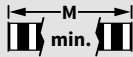

* optional at a surcharge

Colours similar to those in the RAL chart. Colours may differ slightly from those depicted in both hue and finish.

- 01
- 02
- 03
- 04
- 05
- 06
- 07
- 08
- 09
- 10
- 11
- 12
- 13
- 14
- 15
- 16
- 17
- 18
- 19
- 20
- 21
- 22
- 23

Dimensions and configuration options

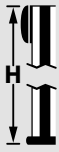
																
		250	300	350	400	450	500	550	600	650	700 ¹⁾					
		167 250	251 300	301 350	351 400	401 450	451 500	501 550	551 600	601 650	651 700					
	150	2)										180	167	430	182	169
	200	2)										230	217	480	232	219
	250	-	2)									280	267	530	282	269
	300	-	-	2)								330	317	580	332	319
	350	-	-	-	2)					2)		380	367	630	382	369
	400 ¹⁾	-	-	-	-	2)				-		430	417	680	432	419

single unit, dimensions in cm

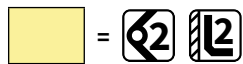

- 1) awnings with 3 arms or a projection of 400 cm are only available with motor
- 2) please note the minimum widths!

Operation / Drive

	standard	optional
manual operation	<input checked="" type="checkbox"/>	-
servo-assisted operation	-	<input checked="" type="checkbox"/>
hard-wired motor	-	<input checked="" type="checkbox"/>
io radio controls	-	<input checked="" type="checkbox"/>
radio-controlled motor (433 MHz)	-	<input checked="" type="checkbox"/>

Dimensions and tolerances

	width		pro- jection
	motor driven	manual	
housing tolerances	+5 / -5 mm		±40 mm
awning cover width = awning width	-100 mm ³⁾	-135 mm	
	-125 mm ⁴⁾		
awning cover length = awning projection			+150 mm

- 3) 2 folding arms
- 4) 3 folding arms







Covers

	fabric range no.	standard	optional
sunsilk snc	324 .. / 328 .. / 369 ..	<input checked="" type="checkbox"/>	-
sunsilk perla FR	374 ..	-	<input checked="" type="checkbox"/>
sunvas snc	310 .. / 311 ..	<input checked="" type="checkbox"/>	-
	313 .. - 315 ..		
sunvas perla	370 ..	-	<input checked="" type="checkbox"/>

Coupled units

	standard	optional
2 fields	-	<input checked="" type="checkbox"/>
3 fields	-	<input checked="" type="checkbox"/>
junction roller	-	<input checked="" type="checkbox"/> ⁵⁾
one-piece cover	-	<input checked="" type="checkbox"/> ⁶⁾

- 5) see overview "Bracket fixture range"
- 6) up to a maximum awning pitch of 15°, up to a maximum projection of 350 cm

 = motor	 = manual operation	M = awning width
 = no. of folding arms	 = no. of bespoke arms	M min. = minimum widths
 = no. of brackets	 = no. of rolltex bearings	H = projection

Miscellaneous

	standard	optional
bionic tendon	<input checked="" type="checkbox"/>	—
system coverboard	—	<input checked="" type="checkbox"/>
insertable side blind	—	<input checked="" type="checkbox"/>
light and wind sensor	—	<input checked="" type="checkbox"/>
valance	<input checked="" type="checkbox"/> ¹⁾	—
infrared heater	—	<input checked="" type="checkbox"/>
vibrabox / radio control light sensor Sunis WireFree	—	<input checked="" type="checkbox"/>

1) valance shape 2
(please refer to the section “Additional Information”)

Frame colours

		standard	optional
traffic white	RAL 9016	<input type="checkbox"/>	
metallic aluminium	RAL 9006	<input type="checkbox"/>	
grey brown, similar to	RAL 8019		<input type="checkbox"/>
light ivory	RAL 1015		<input type="checkbox"/>
anthracite metallic	5204	<input type="checkbox"/>	
stone grey metallic	5215	<input type="checkbox"/>	
off-white textured finish	5233	<input type="checkbox"/>	
Havanna brown textured finish	5229		<input type="checkbox"/>
non-standard powder-coated finish			

Other end cap colour options

	standard	optional
polished chrome		<input type="checkbox"/>

Additional information

The width of the awning cover is always **less** than that of the awning. In the case of coupled units and those with more than 3 arms, please refer cover sizes to us.

Definition of operating side: the operating side is always given as if seen from the outside (right or left).

Pitch adjustment range: from 5° to 50° (to the horizontal).

Definition of projection:
Please consult the section “Technical Information”.

In the case of manual operation approximately **16 winding handle revolutions can be assumed per metre of awning projection.**

It takes approximately **12 seconds per metre** to extend a **motor-driven awning.**

Coupled folding-arm awnings are available up to a **max. of 3 single units** side by side, however **only with a motor.**

A coupled unit is available with **junction roller**. Pattern repeat mismatches are possible in the case of junction roller covers. A junction roller may not fit when the projection is the maximum for the width of each awning. (see also the section on “Installation”, the arm separation table).

If coupled awnings are fitted into a **recess or reveal** the overall width of the coupled awning must be at least 6 cm less than the width of the opening to allow the awning to be coupled.

Colours similar to those in the RAL chart. Colours may differ slightly from those depicted in both hue and finish.

01
02
03
04
05
06
07
08
09
10
11
12
13
14
15
16
17
18
19
20
21
22
23

Fixtures, fittings and accessories

Fixture brackets

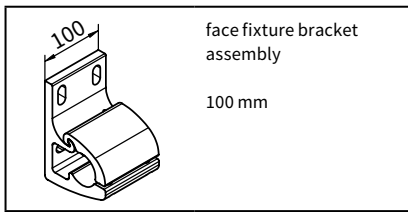

face fixture bracket assembly
100 mm

70867.

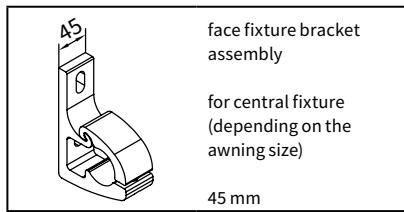

face fixture bracket assembly
for central fixture (depending on the awning size)
45 mm

71813.

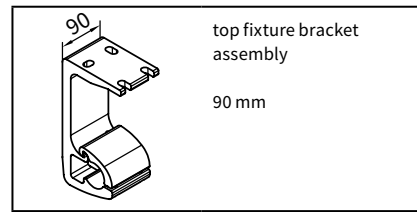

top fixture bracket assembly
90 mm

70868.

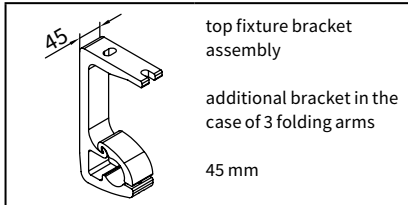

top fixture bracket assembly
additional bracket in the case of 3 folding arms
45 mm

71818.

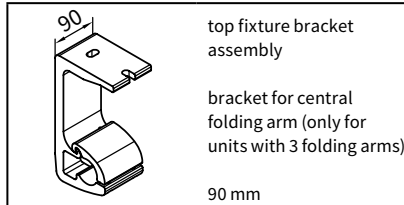

top fixture bracket assembly
bracket for central folding arm (only for units with 3 folding arms)
90 mm

70869.

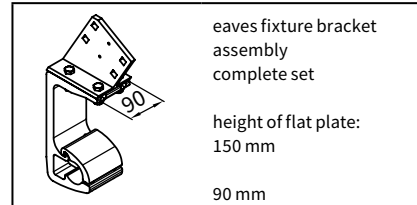

eaves fixture bracket assembly complete set
height of flat plate: 150 mm
90 mm

70871.

Spreader and spacer plates

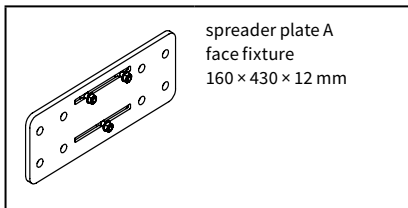

spreader plate A face fixture
160 x 430 x 12 mm

75326.

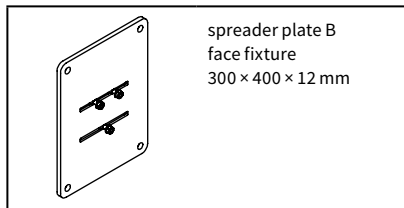

spreader plate B face fixture
300 x 400 x 12 mm

75325.

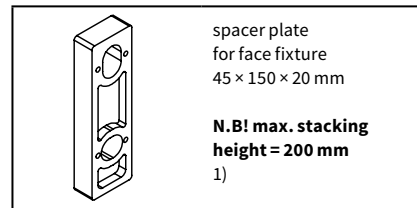

spacer plate for face fixture
45 x 150 x 20 mm

N.B! max. stacking height = 200 mm
1)

718251

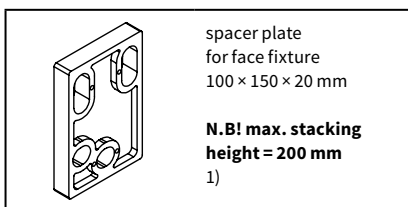

spacer plate for face fixture
100 x 150 x 20 mm
N.B! max. stacking height = 200 mm
1)

718231

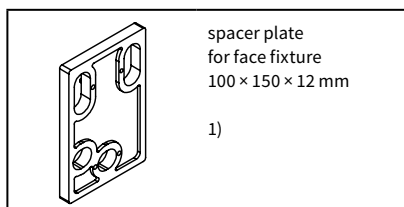

spacer plate for face fixture
100 x 150 x 12 mm
1)

718241

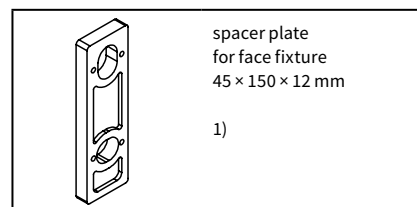

spacer plate for face fixture
45 x 150 x 12 mm
1)

71826.

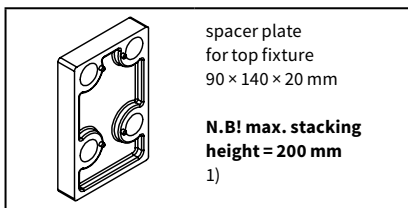

spacer plate for top fixture
90 x 140 x 20 mm
N.B! max. stacking height = 200 mm
1)

716311

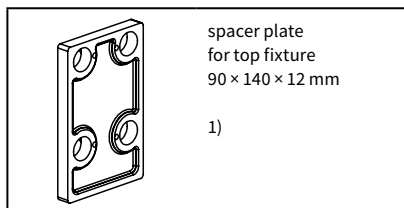

spacer plate for top fixture
90 x 140 x 12 mm
1)

716411

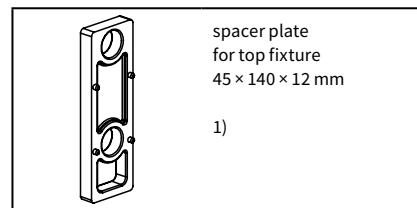

spacer plate for top fixture
45 x 140 x 12 mm
1)

716371

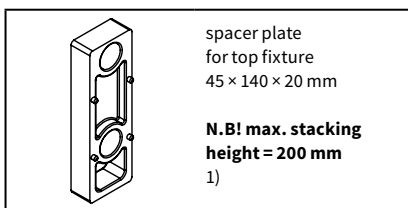

spacer plate for top fixture
45 x 140 x 20 mm
N.B! max. stacking height = 200 mm
1)

716261

1) please refer to the section "Technical Information"

. = insert RAL colour code no

Stand-off brackets

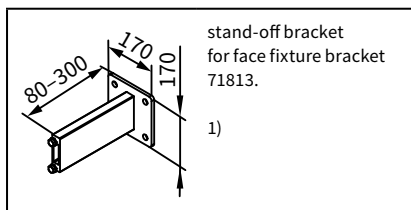

stand-off bracket for face fixture bracket 71813.

1)

77967.

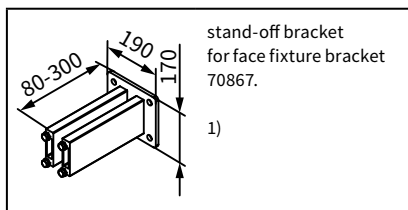

stand-off bracket for face fixture bracket 70867.

1)

77968.

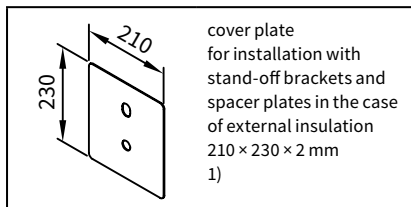

cover plate for installation with stand-off brackets and spacer plates in the case of external insulation 210 x 230 x 2 mm

1)

71844.

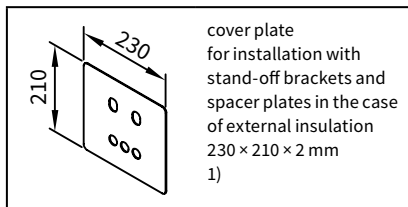

cover plate for installation with stand-off brackets and spacer plates in the case of external insulation 230 x 210 x 2 mm

1)

71843.

Accessories

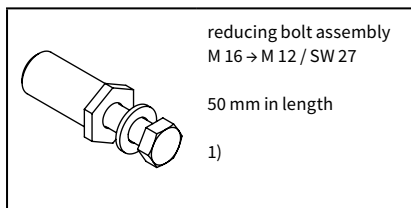

reducing bolt assembly M 16 → M 12 / SW 27

50 mm in length

1)

753891

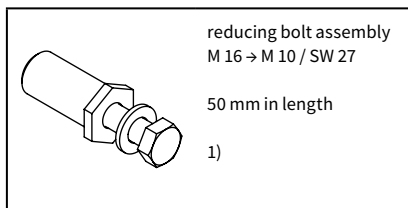

reducing bolt assembly M 16 → M 10 / SW 27

50 mm in length

1)

754921

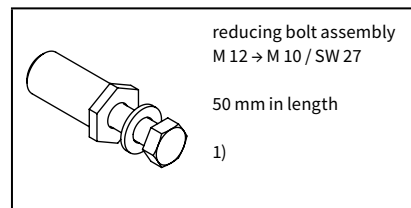

reducing bolt assembly M 12 → M 10 / SW 27

50 mm in length

1)

754911

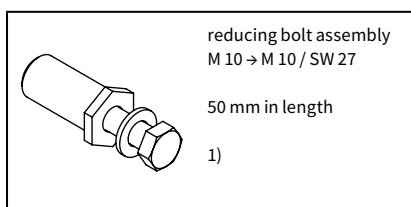

reducing bolt assembly M 10 → M 10 / SW 27

50 mm in length

1)

754901

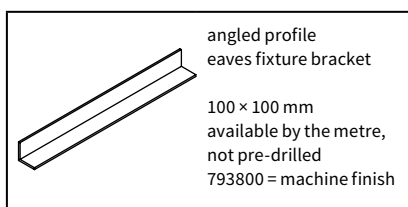

angled profile eaves fixture bracket

100 x 100 mm available by the metre, not pre-drilled 793800 = machine finish

79380.

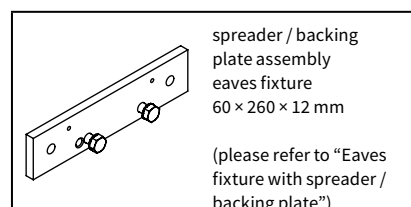

spreader / backing plate assembly eaves fixture 60 x 260 x 12 mm

(please refer to "Eaves fixture with spreader / backing plate")

75383.

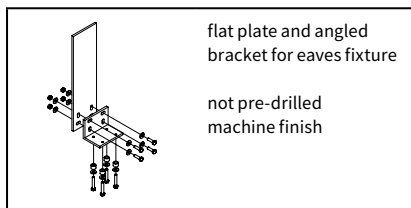

flat plate and angled bracket for eaves fixture

not pre-drilled machine finish

716620

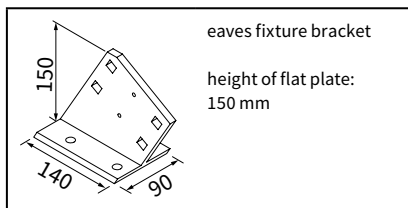

eaves fixture bracket

height of flat plate: 150 mm

71612.

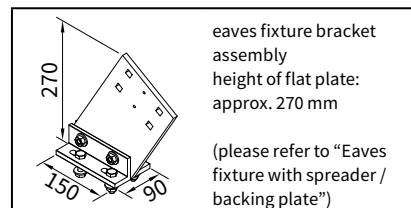

eaves fixture bracket assembly

height of flat plate: approx. 270 mm

(please refer to "Eaves fixture with spreader / backing plate")

71659.

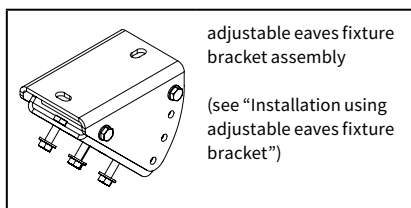

adjustable eaves fixture bracket assembly

(see "Installation using adjustable eaves fixture bracket")

71198.

1) please refer to the section "Technical Information"

. = insert RAL colour code no

Face fixture

Pull-out force [N=Newton] per upper fixing point according to EN 13561, wind resistance class 2

compression-proof substrate

non compression-proof substrate

compression-proof substrate											non compression-proof substrate											
M [cm]											M [cm]											
H [cm]											FB [N]											
	250	300	350	400	450	500	550	600	650	700		250	300	350	400	450	500	550	600	650	700	
150	379	434	489	544	599	654	709	763	818	715	544	622	701	780	858	937	1016	1094	1173	1025		
200	636	724	813	901	989	1077	1165	1254	1342	1218	912	1038	1165	1291	1418	1544	1670	1797	1923	1745		
250	-	1041	1170	1299	1429	1558	1687	1816	2215	2047	-	1493	1678	1863	2048	2233	2418	2603	3175	2934		
300	-	-	1591	1768	1945	2123	2629	2837	3045	2849	-	-	2280	2534	2788	3043	3769	4067	4365	4083		
350	-	-	-	2369	2602	3242	3516	3791	3625	3882	-	-	-	3395	3729	4646	5040	5434	5195	5564		
400	-	-	-	-	3759	4110	4461	4812	-	4873	-	-	-	-	5388	5891	6394	6897	-	6985		
HT BHT	2 100 mm				2 100 mm 1 45 mm			3 100 mm 1 45 mm				2 100 mm				2 100 mm 1 45 mm			3 100 mm 1 45 mm			
BM	6				8			11				6				8			11			

The pull-out force refers to the vertical centre to centre measurement between the fixture points of **90 mm**. If this measurement is reduced to the minimum, the pull-out force increases by **14%** in the case of **compression-proof substrates** and by **19%** in the case of **non compression-proof substrates**.

If the awning is fixed with 2 brackets per folding arm, the pull-out force can be halved.

Place the brackets immediately to the left and right of the arm bearer.

- M = awning width
- H = projection
- FB = pull-out force per fixing point
- HT | BHT = bracket quantity | width
- BM = no. of fixing points
- 71813. = face fixture bracket assembly 45 mm
- 70867. = face fixture bracket assembly 100 mm

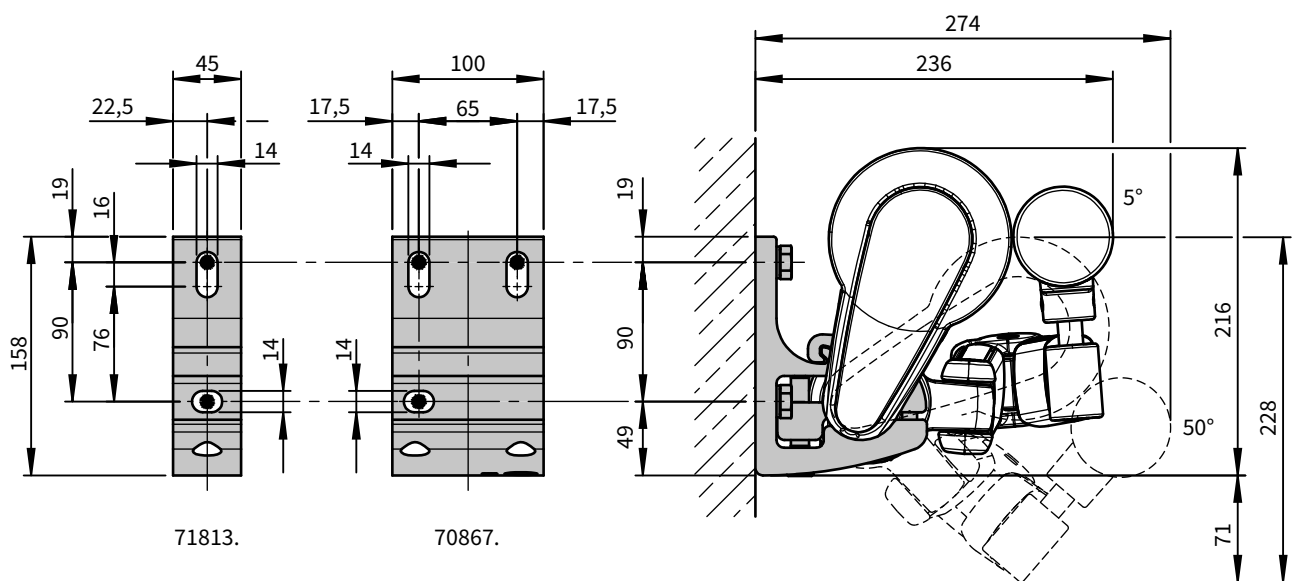

dimensions in mm

Face fixture with spreader plate A

Pull-out force [N=Newton] per upper fixing point according to EN 13561, wind resistance class 2

compression-proof substrate											non compression-proof substrate										
M [cm]											M [cm]										
H [cm]											H [cm]										
FB [N]											FB [N]										
250	300	350	400	450	500	550	600	650	700		250	300	350	400	450	500	550	600	650	700	
150	230	263	296	329	362	395	428	462	495	406	326	373	420	467	515	562	609	656	703	578	
200	384	437	490	543	596	650	703	756	809	685	545	621	696	772	848	923	999	1074	1150	973	
250	-	627	705	782	860	938	1015	1093	1334	1162	-	891	1001	1112	1222	1333	1443	1553	1896	1652	
300	-	-	957	1063	1170	1277	1581	1706	1831	1620	-	-	1359	1511	1662	1814	2247	2425	2602	2302	
350	-	-	-	1423	1563	1948	2113	2278	2042	2196	-	-	-	2022	2222	2768	3003	3237	2902	3121	
400	-	-	-	-	2257	2468	2678	2889	-	2761	-	-	-	-	3208	3507	3806	4106	-	3923	
HT BHT	2 100 mm			2 100 mm 1 45 mm			3 100 mm 1 45 mm				2 100 mm			2 100 mm 1 45 mm			3 100 mm 1 45 mm				
BP	2			2			3				2			2			3				
DP	-			1			1				-			1			1				
BM	16			18			26				16			18			26				

The pull-out force refers to the vertical centre to centre measurement between the fixture points of 76 mm. In the case of spreader plates a washer conforming to DIN 9021 must be used.

- M = awning width
- H = projection
- FB = pull-out force per fixing point
- HT | BHT = bracket quantity | width
- BP = no. of spreader plates
- DP = no. of spacer plates
- BM = no. of fixing points

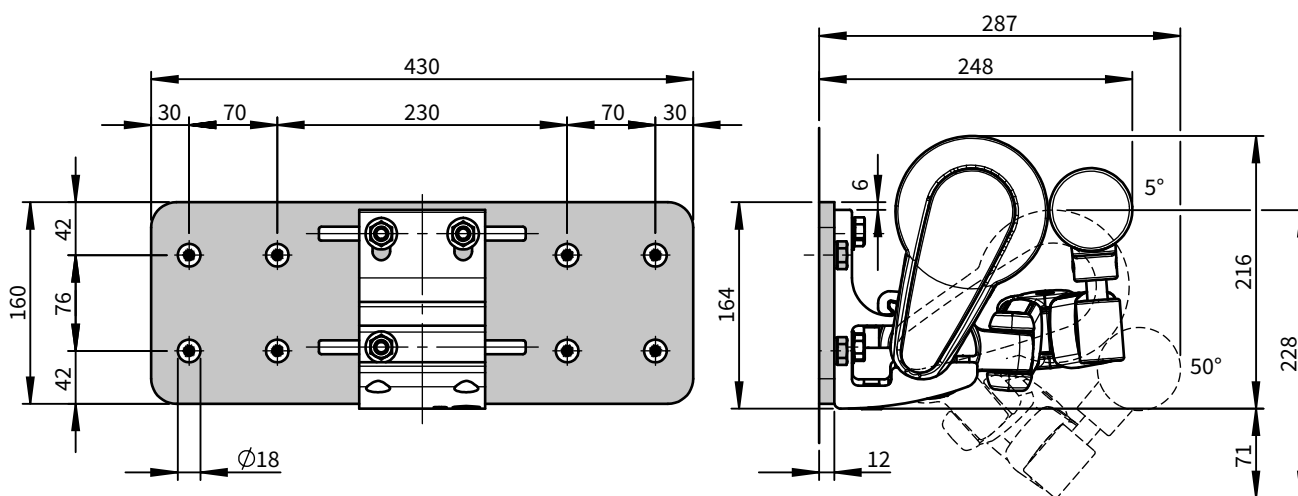

dimensions in mm

01
02
03
04
05
06
07
08
09
10
11
12
13
14
15
16
17
18
19
20
21
22
23

Face fixture with spreader plate B

Pull-out force [N=Newton] per upper fixing point according to EN 13561, wind resistance class 2

compression-proof substrate
M [cm]

250	300	350	400	450	500	550	600	650	700
-----	-----	-----	-----	-----	-----	-----	-----	-----	-----

non compression-proof substrate
M [cm]

250	300	350	400	450	500	550	600	650	700
-----	-----	-----	-----	-----	-----	-----	-----	-----	-----

H [cm]	FB [N]									
150	136	155	175	195	214	234	254	273	293	241
200	227	259	290	322	353	384	416	447	479	405
250	-	371	417	463	509	555	601	647	789	688
300	-	-	566	629	692	755	936	1010	1084	959
350	-	-	-	842	925	1153	1250	1348	1209	1300
400	-	-	-	-	1336	1460	1585	1710	-	1634

H [cm]	FB [N]									
150	142	162	183	203	223	244	264	285	305	251
200	237	270	302	335	368	401	434	467	499	423
250	-	387	435	483	531	579	627	675	823	717
300	-	-	590	656	722	788	976	1053	1130	1000
350	-	-	-	878	965	1202	1304	1406	1260	1355
400	-	-	-	-	1393	1523	1653	1783	-	1704

HT BHT	2 100 mm	2 100 mm 1 45 mm	3 100 mm 1 45 mm
BP	2	2	3
DP	-	1	1
BM	8	10	14

HT BHT	2 100 mm	2 100 mm 1 45 mm	3 100 mm 1 45 mm
BP	2	2	3
DP	-	1	1
BM	8	10	14

HT BHT	2 100 mm	2 100 mm 1 45 mm	3 100 mm 1 45 mm
BP	2	2	3
DP	-	1	1
BM	8	10	14

HT BHT	2 100 mm	2 100 mm 1 45 mm	3 100 mm 1 45 mm
BP	2	2	3
DP	-	1	1
BM	8	10	14

The pull-out force refers to the vertical centre to centre measurement between the fixture points of **350 mm**.
In the case of spreader plates a washer conforming to DIN 9021 must be used.

- M = awning width
- H = projection
- FB = pull-out force per fixing point
- HT | BHT = bracket quantity | width
- BP = no. of spreader plates
- DP = no. of spacer plates
- BM = no. of fixing points

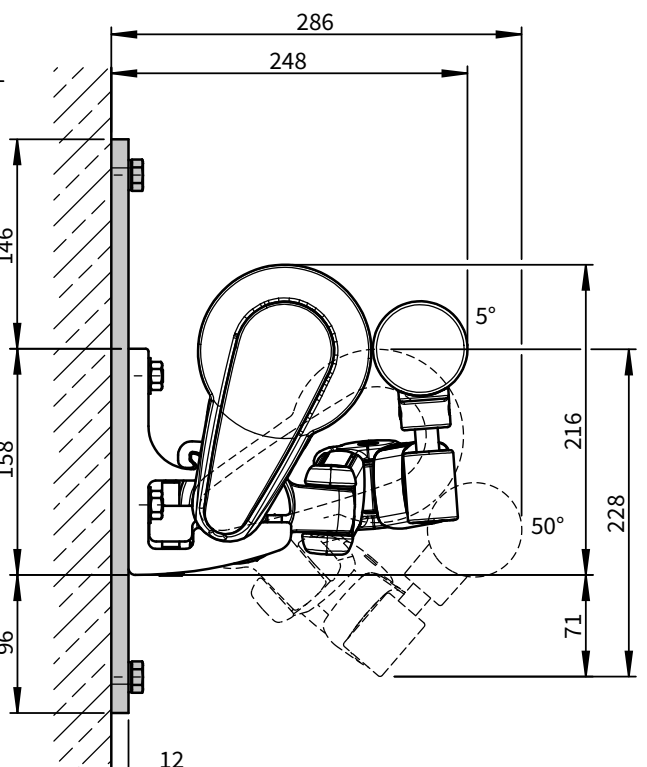
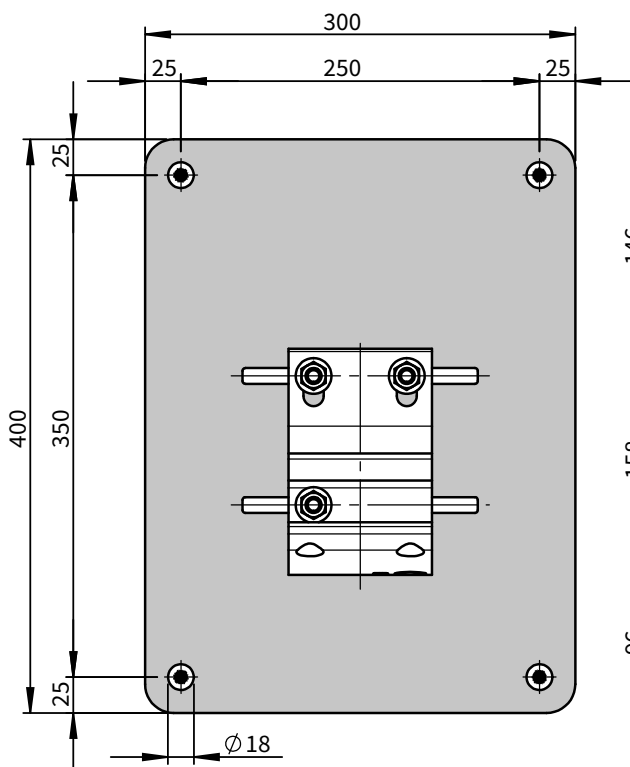

dimensions in mm

Face fixture with stand-off brackets

Pull-out force [N=Newton] per upper fixing point according to EN 13561, wind resistance class 2

compression-proof substrate											non compression-proof substrate											
M [cm]											M [cm]											
H [cm]											H [cm]											
FB [N]											FB [N]											
250	300	350	400	450	500	550	600	650	700		250	300	350	400	450	500	550	600	650	700		
150	479	547	615	683	751	820	888	956	1024	841	538	615	692	769	845	922	999	1076	1152	946		
200	761	865	970	1074	1178	1283	1387	1492	1596	1350	856	973	1091	1208	1326	1443	1561	1678	1796	1519		
250	-	1200	1347	1495	1643	1791	1938	2086	2551	2223	-	1350	1516	1682	1848	2014	2181	2347	2870	2500		
300	-	-	1785	1983	2181	2379	2952	3185	3418	3023	-	-	2008	2231	2454	2677	3321	3583	3845	3401		
350	-	-	-	2607	2863	3571	3873	4175	3743	4024	-	-	-	2932	3220	4017	4357	4697	4211	4527		
400	-	-	-	-	4079	4459	4839	5219	-	4987	-	-	-	-	4589	5016	5444	5871	-	5610		
HT BHT	2 100 mm				2 100 mm 1 45 mm			3 100 mm 1 45 mm				2 100 mm				2 100 mm 1 45 mm			3 100 mm 1 45 mm			
DH 77968.	2				2			3				2				2			3			
DH 77967.	-				1			1				-				1			1			
BM	8				12			16				8				12			16			

The pull-out force refers to the vertical centre to centre measurement between the fixture points of 120 mm.

In the case of stand-off brackets washers conforming to DIN 9021 must be used.

- M = awning width
- H = projection
- FB = pull-out force per fixing point
- HT | BHT = bracket quantity | width
- BM = no. of fixing points
- DH = no. of stand-off brackets
- 77967. = stand-off bracket for face fixture bracket assembly 71813.
- 77968. = stand-off bracket for face fixture bracket assembly 70867.

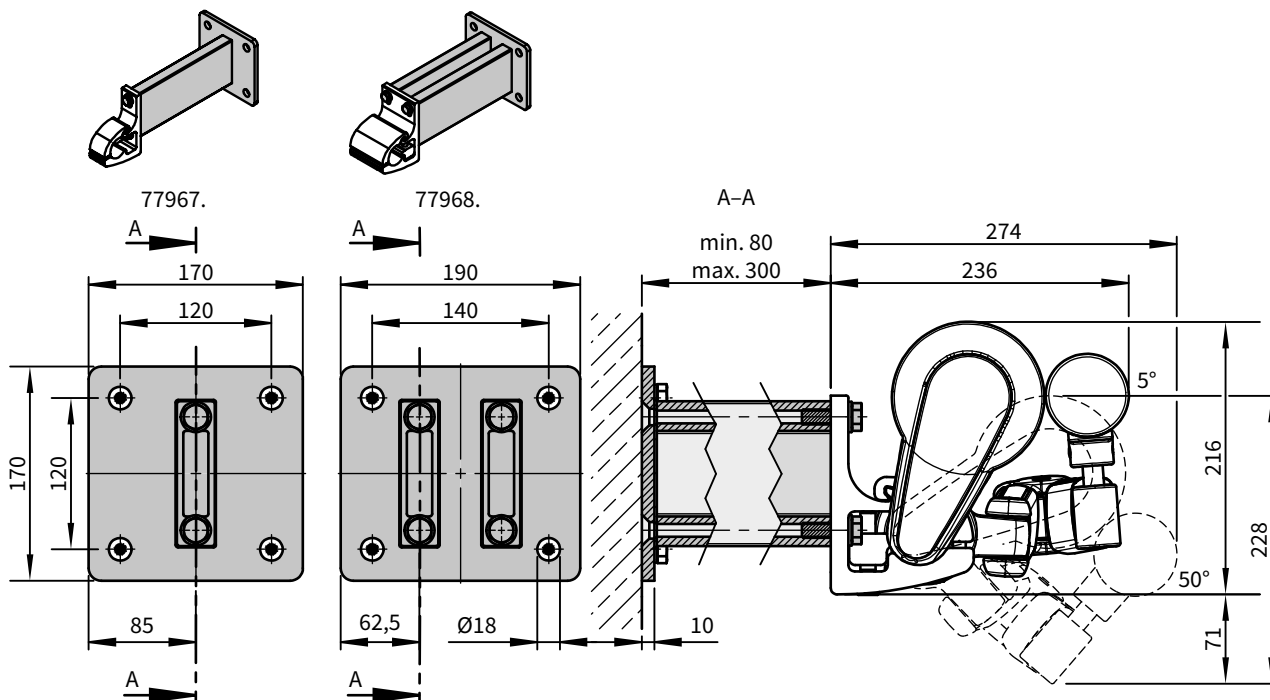

dimensions in mm

Top fixture

Pull-out force [N=Newton] per upper fixing point according to EN 13561, wind resistance class 2

compression-proof substrate
M [cm]

250	300	350	400	450	500	550	600	650	700
-----	-----	-----	-----	-----	-----	-----	-----	-----	-----

H [cm]

FB [N]

150	488	562	636	710	784	858	932	1006	1080	977
200	776	888	999	1110	1222	1333	1445	1556	1668	1541
250	-	1243	1400	1558	1715	1872	2029	2187	2648	2471
300	-	-	1872	2083	2295	2506	3087	3333	3578	3371
350	-	-	-	2757	3031	3761	4082	4403	4228	4529
400	-	-	-	-	4329	4735	5141	5547	-	5642

non compression-proof substrate
M [cm]

250	300	350	400	450	500	550	600	650	700
-----	-----	-----	-----	-----	-----	-----	-----	-----	-----

FB [N]

674	775	876	977	1078	1179	1280	1381	1482	1328
1088	1243	1398	1552	1707	1862	2017	2171	2326	2138
-	1754	1975	2195	2416	2637	2857	3078	3735	3475
-	-	2652	2951	3249	3548	4377	4725	5073	4769
-	-	-	3919	4308	5352	5808	6263	6007	6435
-	-	-	-	6174	6752	7330	7909	-	8033

HT BHT	2 90 mm	2 90 mm	3 90 mm
		1 45 mm	1 45 mm

2 90 mm	2 90 mm	3 90 mm
	1 45 mm	1 45 mm

BM	8	10	14
----	---	----	----

8	10	14
---	----	----

The pull-out force refers to the vertical centre to centre measurement between the fixture points of **80 mm**. If the awning is fitted with two brackets per folding arm the pull-out force may be halved.

Place the brackets immediately to the left and right of the arm bearer.

M = awning width

H = projection

FB = pull-out force per fixing point

HT | BHT = bracket quantity | width

BM = no. of fixing points

70868. = top fixture bracket assembly 90 mm

71818. = top fixture bracket assembly 45 mm

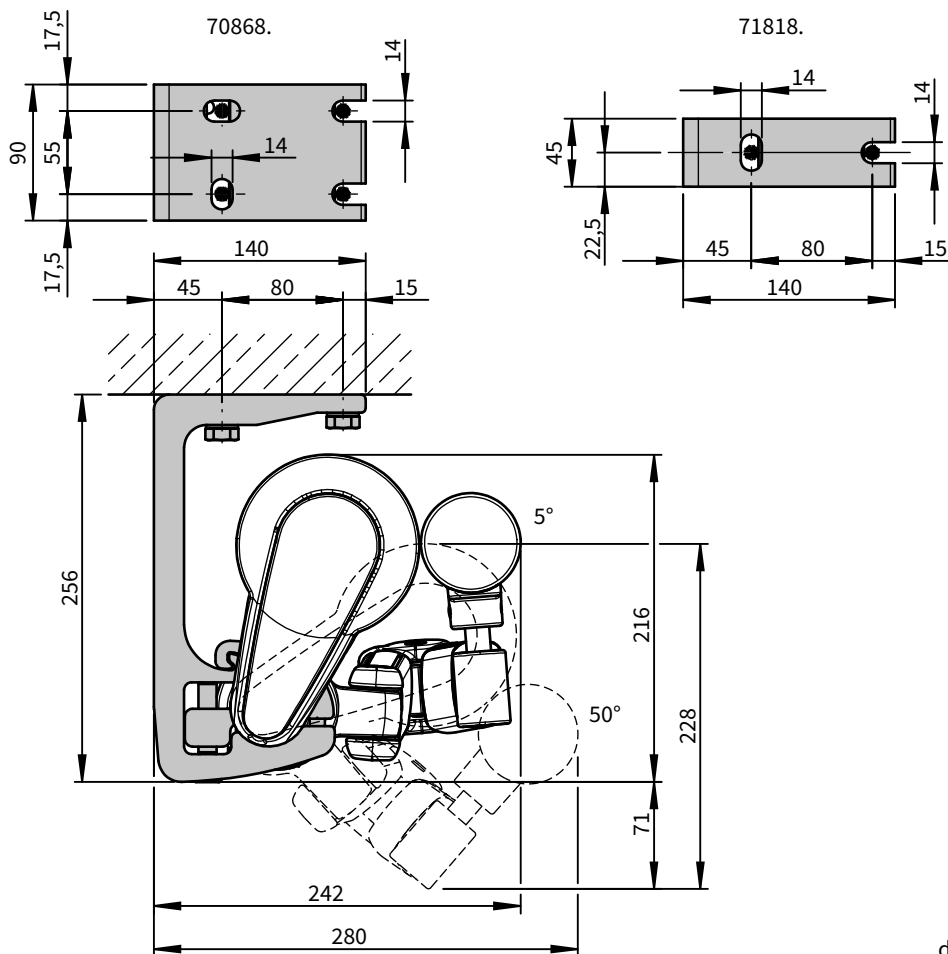

dimensions in mm

Eaves fixture

Torque [Nm = Newton metres] for the fixture bracket next to the arm, shear force [N = Newton] per fixing point according to EN 13561, wind resistance class 2

		Torque M [cm]										Shear force M [cm]									
		250	300	350	400	450	500	550	600	650	700	250	300	350	400	450	500	550	600	650	700
H [cm]	Md [Nm]											FS [N]									
150	98	112	126	140	154	169	183	197	211	185	1213	1395	1577	1759	1942	2124	2306	2488	2671	2401	
200	164	187	210	232	255	278	301	323	346	314	1949	2226	2504	2782	3060	3338	3616	3894	4172	3841	
250	-	269	302	335	369	402	435	468	572	528	-	3135	3530	3925	4320	4715	5110	5505	6676	6217	
300	-	-	410	456	502	548	678	732	786	735	-	-	4735	5268	5802	6335	7812	8433	9054	8517	
350	-	-	-	611	671	836	907	978	935	1002	-	-	-	6990	7684	9543	10356	11168	10715	11478	
400	-	-	-	-	970	1060	1151	1241	-	1257	-	-	-	-	11001	12032	13062	14093	-	14320	
HT		2				3			4			2				3			4		
BM		8				12			16			8				12			16		

The shear force is calculated on the basis of 2 fixing points per bracket, because - depending on the roof pitch - it cannot be guaranteed that 4 fixing points per bracket can be used.

- M = awning width
- H = projection
- Md = torque value for the bracket in the immediate vicinity of the arm
- HT = no. of brackets
- FS = shear force
- BM = no. of fixing points

with eaves fixture bracket 150 mm

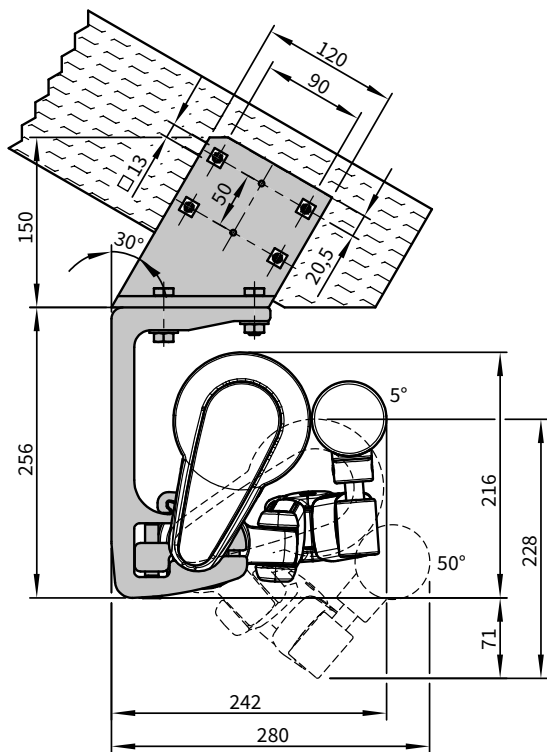

with eaves fixture bracket 270 mm

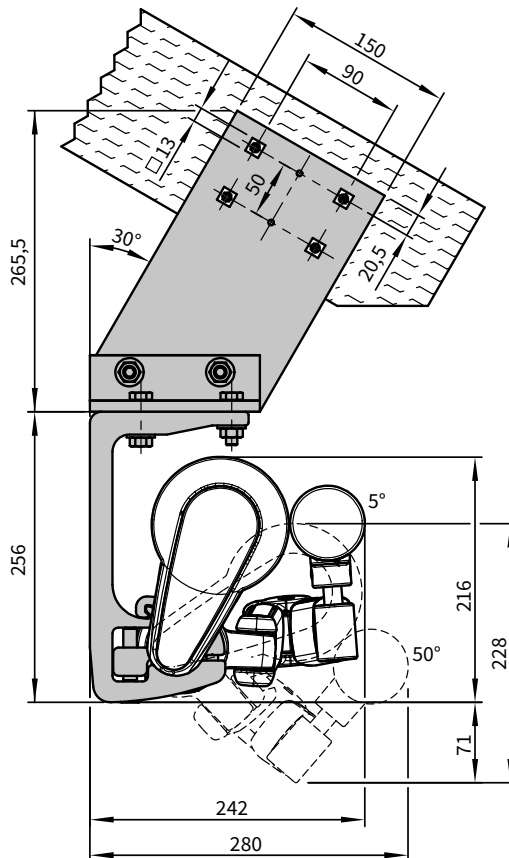

dimensions in mm

01
02
03
04
05
06
07
08
09
10
11
12
13
14
15
16
17
18
19
20
21
22
23

Eaves fixture with additional spreader / backing plate

Torque [Nm = Newton metres] for the fixture bracket in the immediate vicinity of the arm, shear force [N = Newton] per fixing point according to EN 13561, wind resistance class 2

H [cm]	Torque M [cm]										Shear force M [cm]																			
	250	300	350	400	450	500	550	600	650	700	250	300	350	400	450	500	550	600	650	700										
	Md [Nm]										FS [N]																			
150	98	112	126	140	154	169	183	197	211	185	614	710	806	902	997	1093	1189	1285	1380	1273										
200	164	187	210	232	255	278	301	323	346	314	946	1084	1223	1362	1501	1640	1778	1917	2056	1921										
250	-	269	302	335	369	402	435	468	572	528	-	1493	1685	1876	2068	2259	2451	2642	3183	2990										
300	-	-	410	456	502	548	678	732	786	735	-	-	2227	2481	2735	2988	3667	3960	4253	4025										
350	-	-	-	611	671	836	907	978	935	1002	-	-	-	3256	3581	4432	4811	5191	5001	5358										
400	-	-	-	-	970	1060	1151	1241	-	1257	-	-	-	-	5074	5552	6029	6507	-	6637										
HT	2					3					4					2					3					4				
BM	4				6				8		4				6				8											

By using the additional flat fixture plate, the shear force is reduced in comparison with conventional eaves fixture.

- M = awning width
- H = projection
- Md = torque value for the bracket in the immediate vicinity of the arm
- HT = no. of brackets
- FS = shear force
- BM = no. of fixing points

with eaves fixture bracket 150 mm

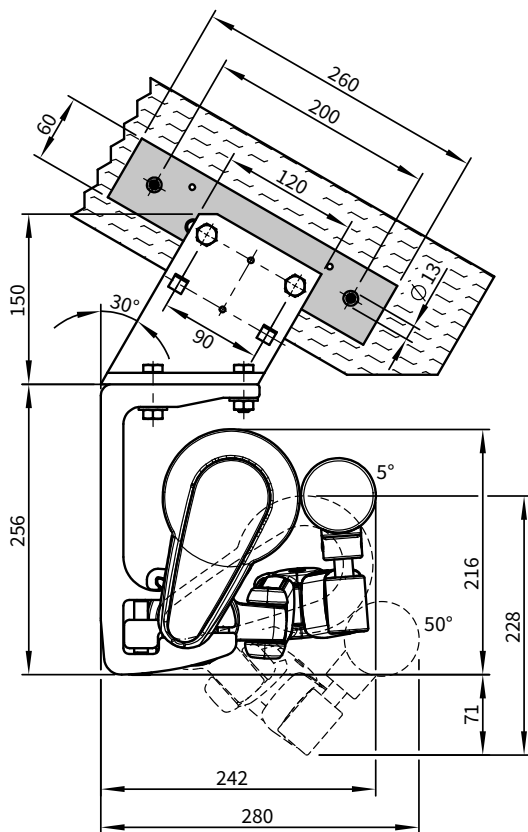

with eaves fixture bracket 270 mm

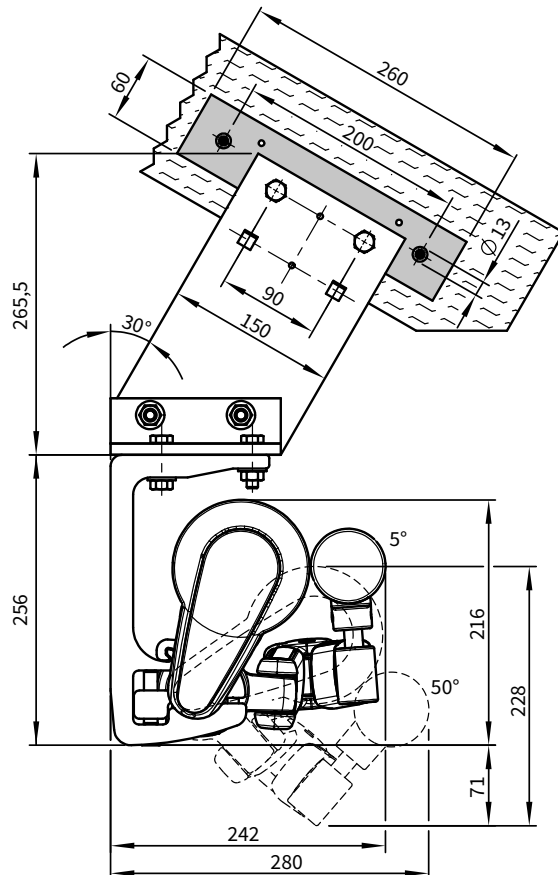

dimensions in mm

Installation using the adjustable eaves fixture bracket

Pull-out force [N=Newton] per upper fixing point according to EN 13561, wind resistance class 2

compression-proof substrate											non compression-proof substrate											
M [cm]											M [cm]											
H [cm]											H [cm]											
FB [N]											FB [N]											
250	300	350	400	450	500	550	600	650	700	250	300	350	400	450	500	550	600	650	700			
150	1027	1193	1358	1524	1690	1855	2021	2187	2353	2101	1059	1230	1401	1571	1742	1913	2084	2254	2425	2163		
200	1559	1798	2038	2277	2517	2756	2996	3235	3475	3173	1610	1857	2104	2351	2599	2846	3093	3340	3587	3274		
250	-	2452	2778	3105	3432	3758	4085	4411	4738	4435	-	2534	2871	3209	3546	3883	4221	4558	4895	4595		
300	-	-	3630	4057	4484	4911	5338	5765	6192	5889	-	-	3754	4195	4636	5077	5518	5959	6400	6100		
350	-	-	-	5244	5785	6326	6867	7408	7949	7646	-	-	-	5424	5983	6542	7101	7660	8219	7816		
HT BHT	2 90 mm				2 90 mm			3 90 mm				2 90 mm				2 90 mm			3 90 mm			
					1 45 mm			1 45 mm								1 45 mm			1 45 mm			
BM	8				10			14				8				10			14			

The pull-out force refers to the measurement from the front to the rear fixture points of 140 mm.

Washers conforming to DIN 9021 must be used.

- M = awning width
- H = projection
- FB = pull-out force per fixing point
- HT | BHT = bracket quantity | width
- BM = no. of fixing points

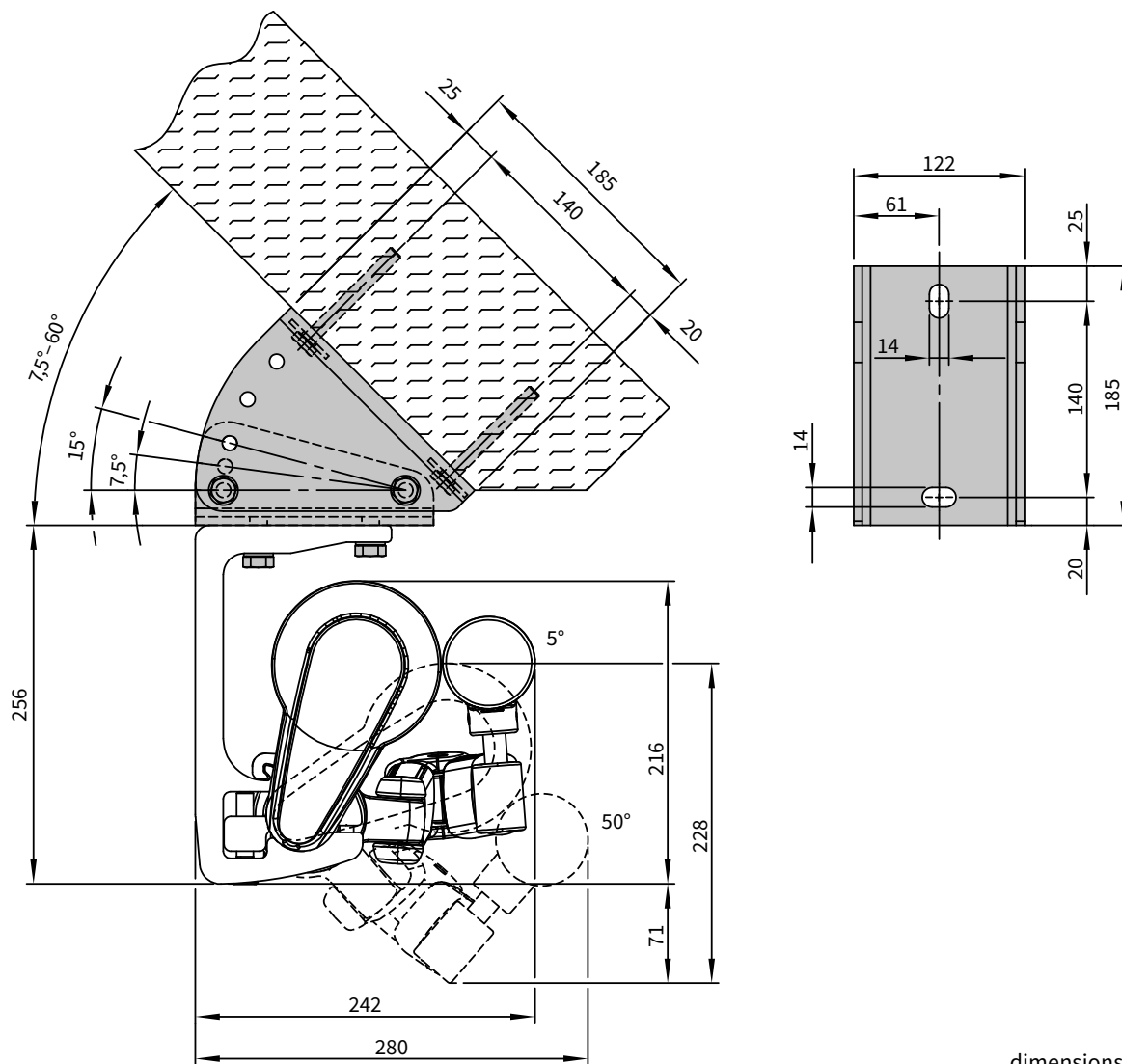

dimensions in mm

01
02
03
04
05
06
07
08
09
10
11
12
13
14
15
16
17
18
19
20
21
22
23

Face fixture with manual operation

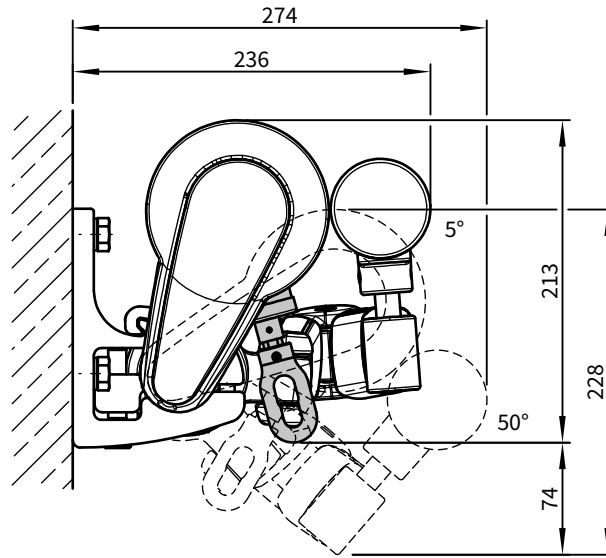

dimensions in mm

Cable exit point on motor-driven units

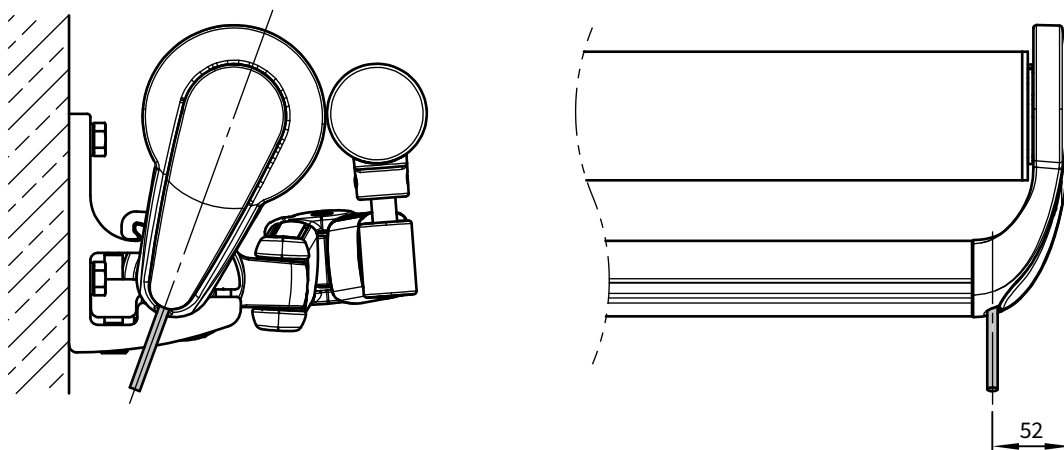

dimensions in mm

markilux system coverboard affixed to the torque bar (optionally with the markilux flexlight)

Face fixture with system coverboard

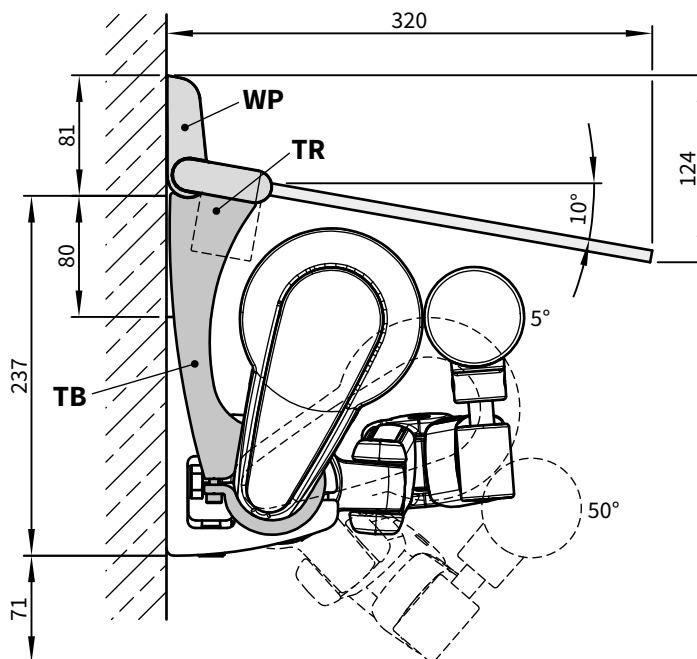

dimensions in mm

View from the front

optionally with markilux flexlight light rope (please refer to the section “Optional Accessories”)

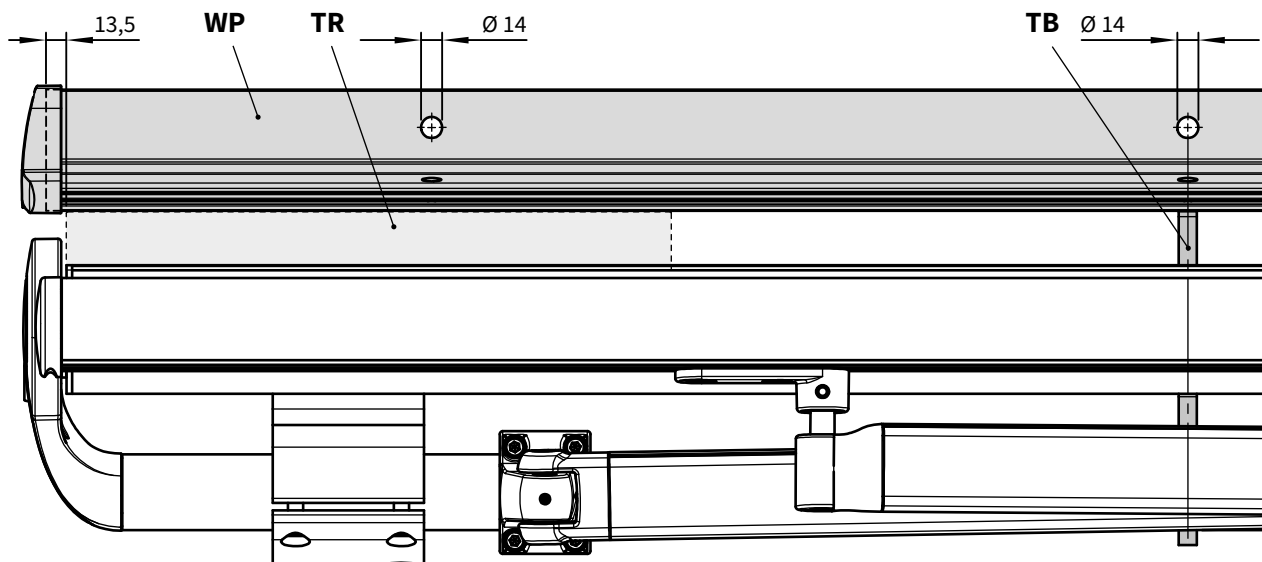

- WP = wall profile
- TR = transformer (for the markilux flexlight)
- TB = torque bar fixture

dimensions in mm

- 01
- 02
- 03
- 04
- 05
- 06
- 07
- 08
- 09
- 10
- 11
- 12
- 13
- 14
- 15
- 16
- 17
- 18
- 19
- 20
- 21
- 22
- 23

No. of fixing points for the markilux system coverboard

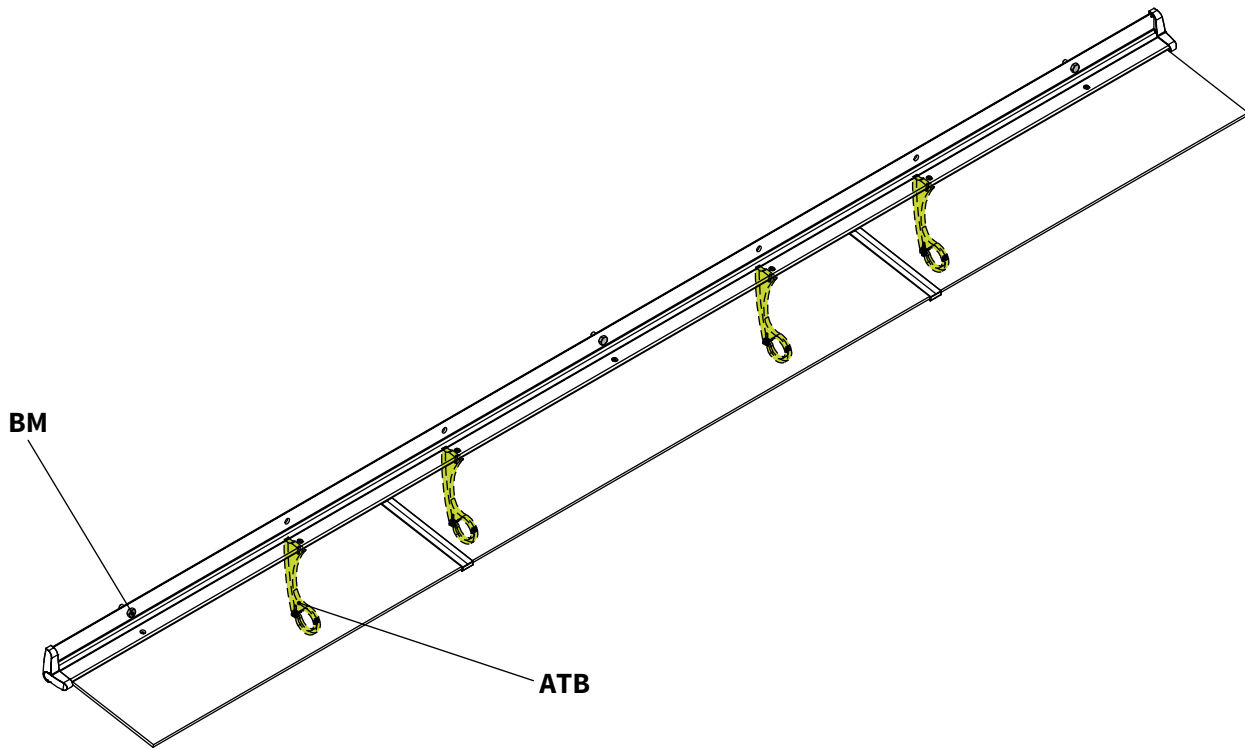

dimensions in mm

No. of fixing points

	M								
	2537–3000	3037–3500	3537–4000	4037–4500	4537–5000	5037–5500	5537–6000	6037–6500	6537–7000
ATB	4	4	4	4	4	4	4	4	4*
BM	4	3	4	3	4	3	4	3	4

M = awning width

ATB = no. of torque bar fixing points for the system coverboard

BM = no. of fixing points, face fixture

* = at a projection of 2000 mm 3 × torque bar fixture points for the system coverboard

Installation dimensions at varying awning pitches

Top fixture

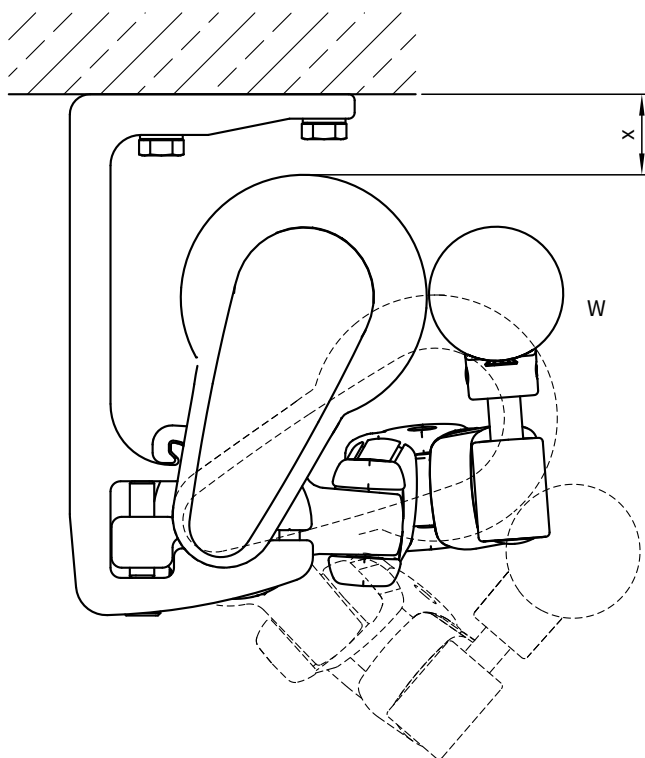

pitch (W)	approx. height in mm (X)
5°	40
10°	44
15°	48
20°	54
25°	60
30°	66
35°	74
40°	82
45°	90
50°	99

Face fixture

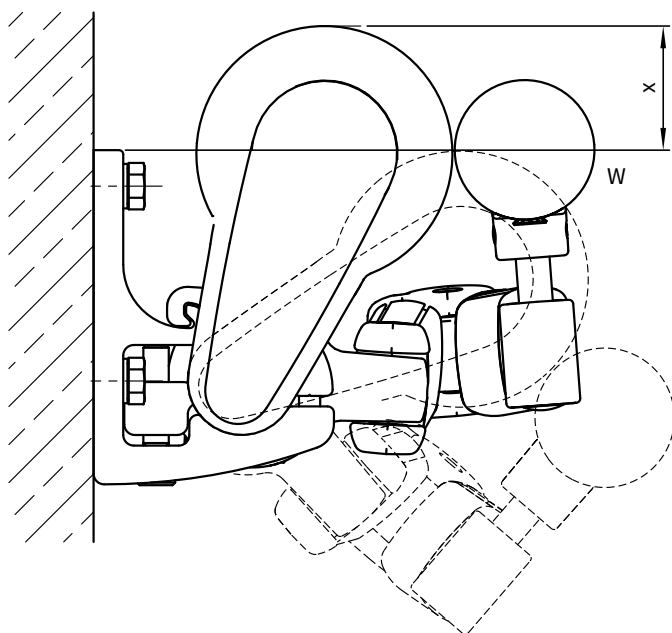

pitch (W)	approx. height in mm (X)
5°	59
10°	55
15°	50
20°	45
25°	39
30°	32
35°	25
40°	17
45°	8
50°	0

- 01
- 02
- 03
- 04
- 05
- 06
- 07
- 08
- 09
- 10
- 11
- 12
- 13
- 14
- 15
- 16
- 17
- 18
- 19
- 20
- 21
- 22
- 23

Bracket fixture range for awnings with 2 folding arms

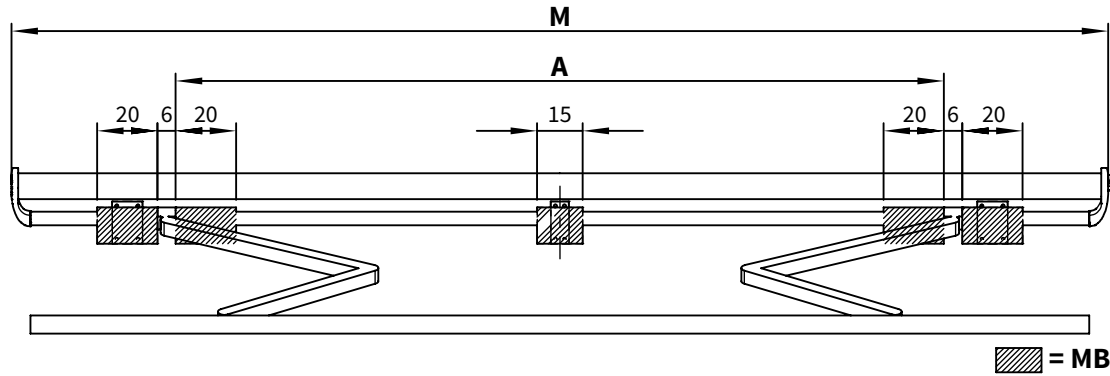

Dimensions in cm

M [cm]	SB →	250	300	350	400	450	500	550	600	650
	ZB →	180–250	251–300	301–350	351–400	401–450	451–500	501–550	551–600	601–650

H [cm] ↓	A [cm]								
150	154*	210	240	280	320	390	425	460	500
200	204**	210*	240	280	320	390	425	460	500
250	-	254**	260*	280	320	390	425	460	500
300	-	-	304**	310*	320	390	425	460	500
350	-	-	-	354**	360*	390	425	460	-
400	-	-	-	-	404**	420*	425	460	-

dimensions in cm

W	BHT ↓	HT ↓	
	45 mm	-	1
	100 mm	2	2

DE	45 mm	-	1
	90 mm	2	2

DA	90 mm	2	3
----	-------	---	---

If the brackets cannot be positioned in accordance with this table, make sure the actual measurements are noted on the order form!

* = Coupled units are only available with a junction roller in the standard widths, in the case of other widths please ask us.

** = Please note the minimum widths! Dimension A is only valid for standard arms! Dimension A is 13 cm smaller in the case of bespoke arms; in the case of small awnings the brackets can only be fitted inside the arms, i.e. the position denoted by dimension A.

- A = arm position
- BHT = bracket width
- DA = eaves fixture
- DE = top fixture
- H = projection
- HT = no. of brackets
- M = awning width
- MB = bracket fixture range
- SB = standard width
- W = face fixture
- ZB = intermediate width

Bracket fixture range for awnings with 3 folding arms

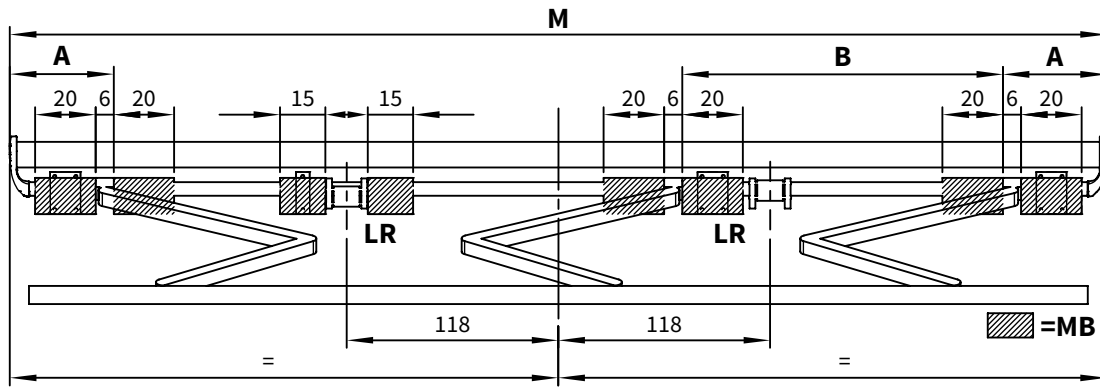

dimensions in cm

M [cm]	SB →	650	700		
	ZB →	630–650	651–664	665–679	680–700

H [cm] ↓	A [cm] ↓	B [cm] ↓	A [cm] ↓	B [cm] ↓	A [cm] ↓	B [cm] ↓	A [cm] ↓	B [cm] ↓	KM [cm] ↓
150	-	-	55	235	55	245	55	245	430
200	-	-	55	225	55	235	55	235	480
250	-	-	55	215	55	225	55	225	530
300	-	-	45	210	55	215	55	215	580
350	13*	215*	23*	215*	31*	225*	38	225	630
400	-	-	-	-	-	-	13*	230*	680

dimensions in cm

W	BHT ↓	HT ↓
	45 mm	1
	100 mm	3

DE	45 mm	1
	90 mm	3

DA	90 mm	4
----	-------	---

If the brackets cannot be positioned in accordance with this table, make sure the actual measurements are noted on the order form!

* = Dimension A is valid only for standard widths: coupled units are not available with junction roller.

A = arm position

B = arm position

BHT = bracket width

DA = eaves fixture

DE = top fixture

H = projection

HT = no. of brackets

KM = minimum awning width

LR = a rolltex bearing with accompanying bracket is always placed under a central seam (depends on the awning size)

M = awning width

MB = bracket fixture range

SB = standard width

W = face fixture

ZB = intermediate width

