



markilux 1710

**Chic, modern, compact – the cover cassette awning
with perfected design features**

**rated to wind resistance class 2
(corresponds to Beaufort 5)**



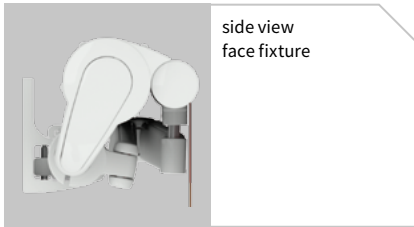

side view
face fixture

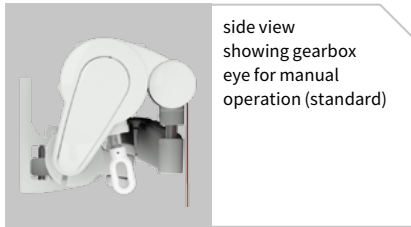

side view
showing gearbox
eye for manual
operation (standard)

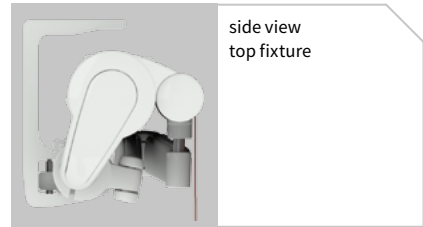

side view
top fixture

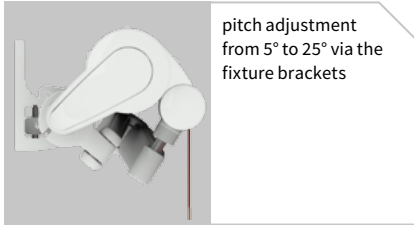

pitch adjustment
from 5° to 25° via the
fixture brackets

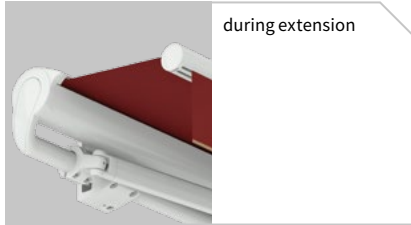

during extension



markilux bionic
tendon made from
high-tech fibres for
ideal power trans-
ference – as standard

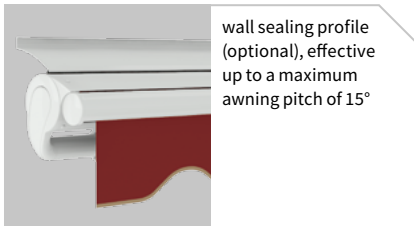

wall sealing profile
(optional), effective
up to a maximum
awning pitch of 15°

Design Features

elegant cover cassette made of extruded aluminium

the special cassette shape surrounds the roller tube even when the awning is extended thus creating an overall harmonious appearance

the transition from torque bar to roller tube is curved and homogeneous

side caps available in polished chrome offer an optional designer touch

Technical Specification

attractive front profile made of extruded aluminium with integrated gutter and water drainage spouts

sturdy, round steel torque bar, 50 mm Ø, to prevent twist and deflection

the 85 mm roller tube ensures the highest stiffness and the best possible cover winding characteristics even at the largest widths

the extremely sturdy awning construction makes it possible to shade even very large areas safely

unique arm technology with power transference by way of the highly tear-resistant bionic tendon made of high-tech fibres, achieving at least 50,000 cycles in tests by the Fraunhofer Institute

Optional Accessories

radio-controlled motor with radio remote control for ease of use

hard-wired motor operation (optionally with automatic weather controls) for straightforward and easy operation

in the case of manual operation ease of use is ensured with the spring-assisted gearbox

wall sealing profile to cover the gap between awning and wall

awning available in non-standard RAL colours

markilux infrared heater in a compact aluminium housing; caressing warmth without heating-up phase within an area of approx. 9–12 m²

Lounge colours

markilux 1710

off-white textured finish 5233

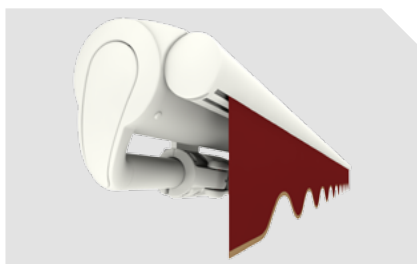

End caps in polished chrome

off-white textured finish 5233

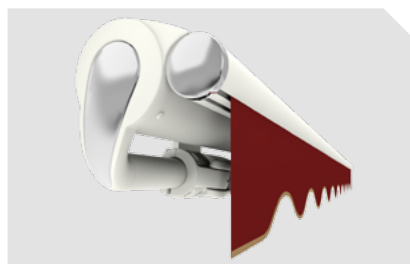

stone grey metallic 5215

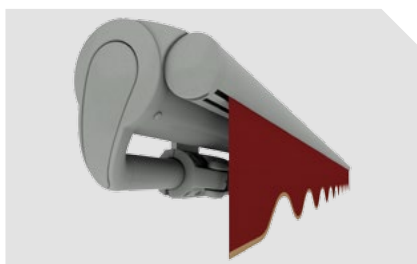

stone grey metallic 5215

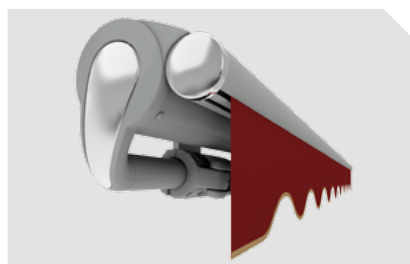

Havana brown textured finish 5229

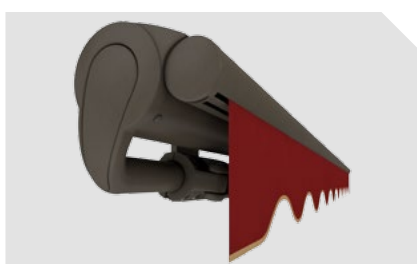

Havana brown textured finish 5229

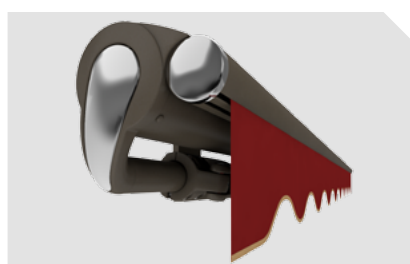

anthracite metallic 5204



anthracite metallic 5204



- 01
- 02
- 03
- 04
- 05
- 06
- 07
- 08**
- 09
- 10
- 11
- 12
- 13
- 14
- 15
- 16
- 17
- 18
- 19
- 20
- 21
- 22
- 23

Colours may differ slightly from those depicted in both hue and finish.

Dimensions and configuration options

		M									M min.					
		250	300	350	400	450	500	550	600	650	700 ¹⁾	M			M	
		167 250	251 300	301 350	351 400	401 450	451 500	501 550	551 600	601 650	651 700	⊗	⊗	⊗	⊗	⊗
H	150	2)										180	167	418	182	169
	200	2)										230	217	468	232	219
	250	-	2)									280	267	518	282	269
	300	-	-	2)								330	317	568	332	319
	350	-	-	-	2)					1)		380	367	618	382	369

dimensions in cm

 =
 =
 =

- 1) awnings with 3 arms are only available with motor (surcharge)
- 2) please note the minimum widths!

Operation / Drive

	standard	optional
manual operation	<input checked="" type="checkbox"/>	-
servo-assisted operation	-	<input checked="" type="checkbox"/>
hard-wired motor	-	<input checked="" type="checkbox"/>
io radio controls	-	<input checked="" type="checkbox"/>
radio-controlled motor (433 MHz)	-	<input checked="" type="checkbox"/>

Coupled units

	standard	optional
2 fields	-	<input checked="" type="checkbox"/> ³⁾
junction roller	-	<input checked="" type="checkbox"/> ⁴⁾

- 3) for minimum widths see "Technical Information"
- 4) please refer to "Bracket fixture range"

Miscellaneous

	standard	optional
bionic tendon	<input checked="" type="checkbox"/>	-
wall sealing profile	-	<input checked="" type="checkbox"/> ⁵⁾
light and wind sensor	-	<input checked="" type="checkbox"/>
valance	<input checked="" type="checkbox"/> ⁶⁾	-
infrared heater	-	<input checked="" type="checkbox"/>
vibrabox / radio control light sensor Sunis WireFree	-	<input checked="" type="checkbox"/>

Covers

	fabric range no.	standard	optional
sunsilk snc	324 .. / 328 .. / 369 ..	<input checked="" type="checkbox"/>	-
sunsilk perla FR	374 ..	-	<input checked="" type="checkbox"/>
sunvas snc	310 .. / 311 .. 313 .. - 315 ..	<input checked="" type="checkbox"/>	-
sunvas perla	370 ..	-	<input checked="" type="checkbox"/>





- 5) up to a maximum awning pitch of 15°
- 6) valance shape 2 (please refer to the section "markilux Collection")

= motor
 = no. of folding arms
 = manual operation
M = awning width

= no. of brackets
 = no. of bespoke arms
 = no. of cassette support brackets
M min. = minimum widths

H = projection

Dimensions and tolerances

	width		projection
			
housing tolerances	+5 / -10 mm		±40 mm
awning cover width = awning width	 → -100 mm	-135 mm	
	 → -125 mm		
awning cover length = awning projection			+150 mm

Frame colours

		standard	optional
traffic white	RAL 9016		
metallic aluminium	RAL 9006		
grey brown, similar to	RAL 8019		
light ivory	RAL 1015		
anthracite metallic	5204		
stone grey metallic	5215		
off-white textured finish	5233		
Havana brown textured finish	5229		
non-standard powder-coated finish			

Other end cap colour options

	standard	optional
polished chrome		

Colours similar to those in the RAL chart. Colours may differ slightly from those depicted in both hue and finish.

Additional information

The width of the awning cover is always **less** than that of the awning. Please refer cover sizes in the case of coupled units and those with more than 3 arms to us.

Definition of operating side: the operating side is always given as if seen from the outside (right or left).

Pitch adjustment range: from 5° to 25° (to the horizontal).

Definition of projection:

Please consult the section “Technical Information”.

In the case of manual operation approximately **16 winding handle revolutions** can be assumed **per metre of awning projection**.

It takes approximately **12 seconds per metre** to extend a **motor-driven awning**.

Coupled folding-arm awnings are available up to a **max. of 2 single units** side by side, however **only with a motor**.

A coupled unit is available with **junction roller**. Pattern repeat mismatches are possible in the case of junction roller covers. A junction roller may not fit when the projection is the maximum for the width of each awning. (see also the section on “Installation”, the arm separation table).

If coupled awnings are fitted into a **recess or reveal** the overall width of the coupled awning must be at least 6 cm less than the width of the opening to allow the awning to be coupled.

01
02
03
04
05
06
07
08
09
10
11
12
13
14
15
16
17
18
19
20
21
22
23

Fixtures, fittings and accessories

Fixture brackets

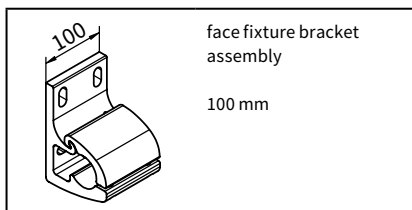

face fixture bracket assembly

100 mm

70867.

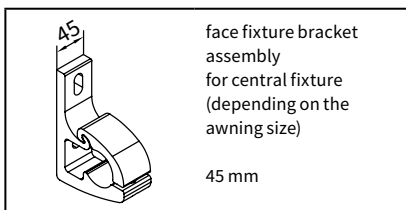

face fixture bracket assembly for central fixture (depending on the awning size)

45 mm

71813.

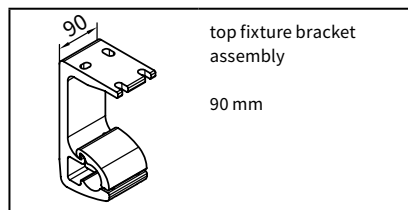

top fixture bracket assembly

90 mm

70868.

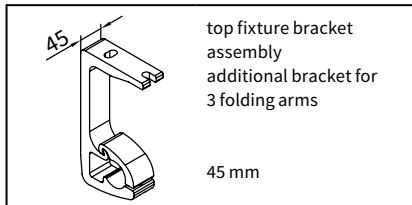

top fixture bracket assembly additional bracket for 3 folding arms

45 mm

71818.

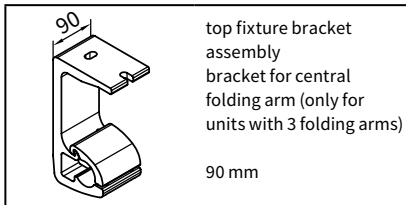

top fixture bracket assembly bracket for central folding arm (only for units with 3 folding arms)

90 mm

70869.

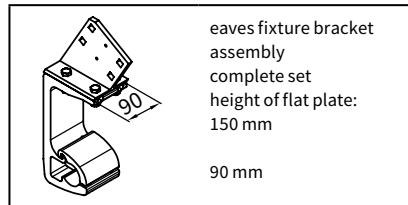

eaves fixture bracket assembly complete set height of flat plate: 150 mm

90 mm

70871.

Spreader and spacer plates

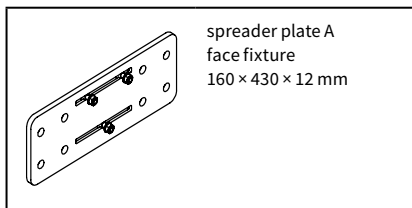

spreader plate A face fixture

160 × 430 × 12 mm

75326.

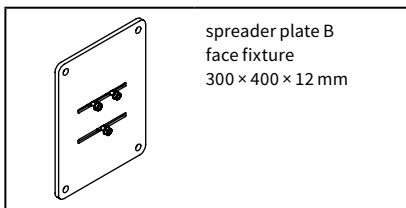

spreader plate B face fixture

300 × 400 × 12 mm

75325.

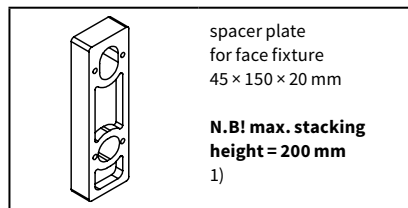

spacer plate for face fixture

45 × 150 × 20 mm

N.B! max. stacking height = 200 mm
1)

718251

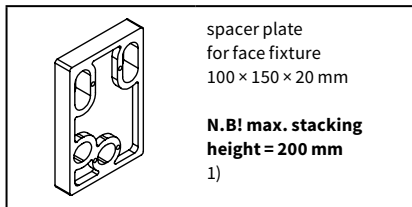

spacer plate for face fixture

100 × 150 × 20 mm

N.B! max. stacking height = 200 mm
1)

718231

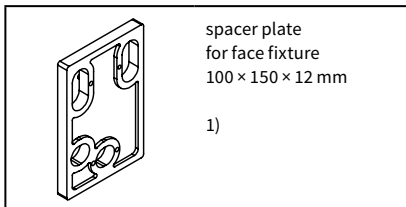

spacer plate for face fixture

100 × 150 × 12 mm

1)

718241

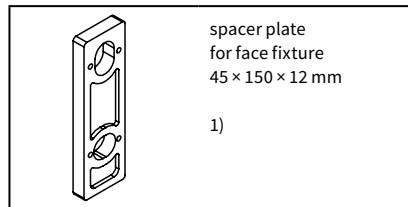

spacer plate for face fixture

45 × 150 × 12 mm

1)

71826.

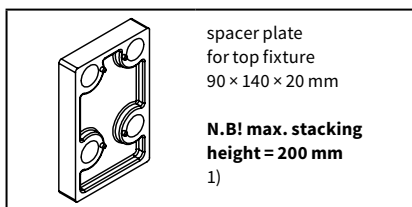

spacer plate for top fixture

90 × 140 × 20 mm

N.B! max. stacking height = 200 mm
1)

716311

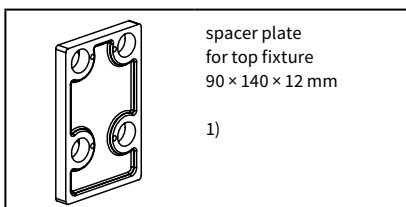

spacer plate for top fixture

90 × 140 × 12 mm

1)

716411

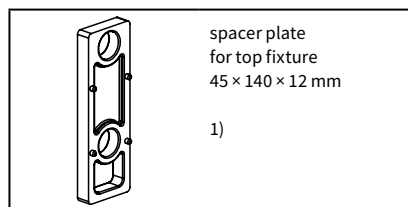

spacer plate for top fixture

45 × 140 × 12 mm

1)

716371

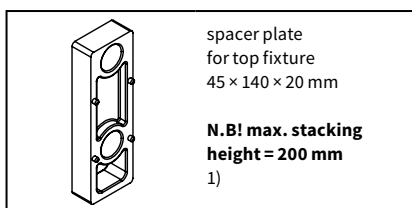

spacer plate for top fixture

45 × 140 × 20 mm

N.B! max. stacking height = 200 mm
1)

716261

1) please refer to the section "Technical Information"

. = insert RAL colour code no

Stand-off brackets

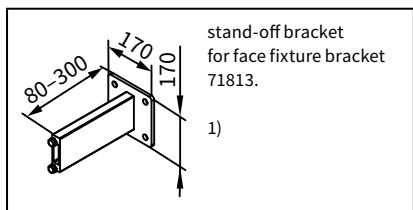

77967.

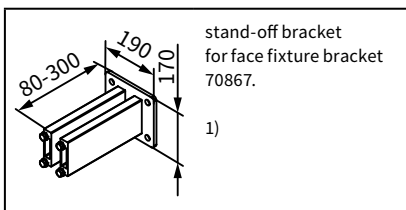

77968.

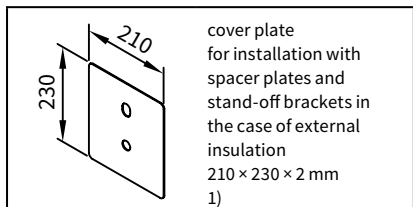

71844.

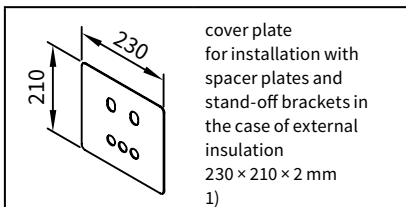

71843.

Accessories

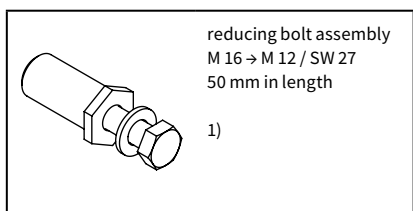

753891

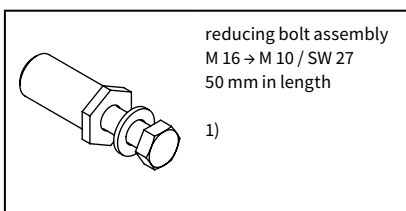

754921

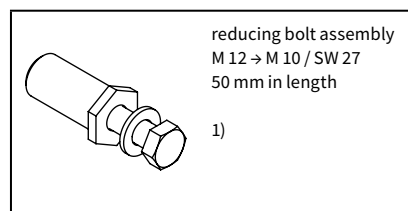

754911

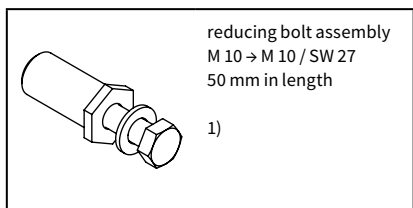

754901

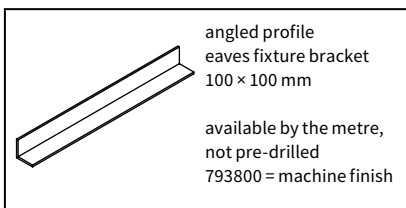

79380.

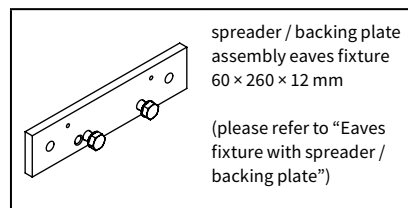

75383.

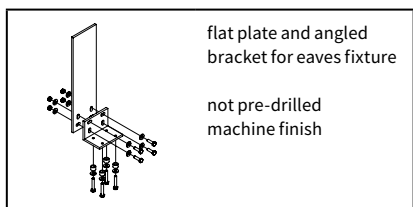

716620

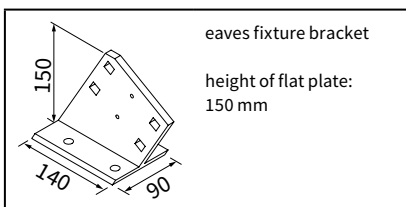

71612.

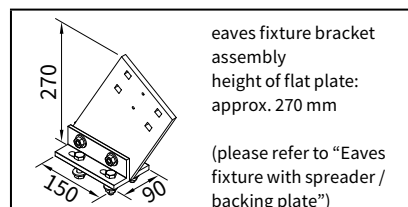

71659.

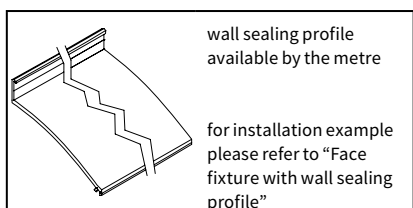

77780.

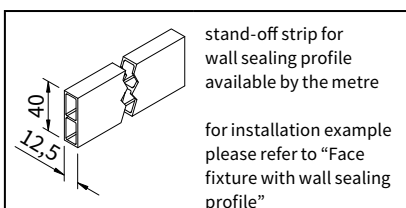

751971

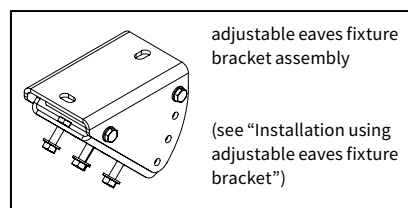

71198.

1) please refer to the section "Technical Information"

. = insert RAL colour code no

Face fixture

Pull-out force [N=Newton] per upper fixing point according to EN 13561, wind resistance class 2

Compression-proof substrate
M [cm]

250	300	350	400	450	500	550	600	650	700
-----	-----	-----	-----	-----	-----	-----	-----	-----	-----

Non Compression-proof substrate
M [cm]

250	300	350	400	450	500	550	600	650	700
-----	-----	-----	-----	-----	-----	-----	-----	-----	-----

H [cm]	FB [N]									
150	379	434	489	544	599	654	709	763	818	715
200	636	724	813	901	989	1077	1165	1254	1342	1218
250	-	1041	1170	1299	1429	1558	1687	1816	2215	2047
300	-	-	1591	1768	1945	2123	2629	2837	3045	2849
350	-	-	-	2369	2602	3242	3516	3791	3625	3882

FB [N]									
544	622	701	780	858	937	1016	1094	1173	1025
912	1038	1165	1291	1418	1544	1670	1797	1923	1745
-	1493	1678	1863	2048	2233	2418	2603	3175	2934
-	-	2280	2534	2788	3043	3769	4067	4365	4083
-	-	-	3395	3729	4646	5040	5434	5195	5564

HT BHT	2 100 mm		2 100 mm 1 45 mm	3 100 mm 1 45 mm
----------	------------	--	-------------------------	-------------------------

HT BHT	2 100 mm		2 100 mm 1 45 mm	3 100 mm 1 45 mm
----------	------------	--	-------------------------	-------------------------

BM	6		8	11
----	---	--	---	----

BM	6		8	11
----	---	--	---	----

The pull-out force refers to the vertical centre to centre measurement between the fixture points of **90 mm**. If this measurement is reduced to the minimum, the pull-out force increases by **14%** in the case of **Compression-proof substrates** and by **19%** in the case of **non compression-proof substrates**.

If the awning is fixed with 2 brackets per folding arm, the pull-out force can be halved.

Place the brackets immediately to the left and right of the arm bearer.

- M = awning width
- H = projection
- FB = pull-out force per fixing point
- HT | BHT = bracket quantity | width
- BM = no. of fixing points
- WA = wall sealing profile
- 71813. = face fixture bracket assembly 45 mm
- 70867. = face fixture bracket assembly 100 mm

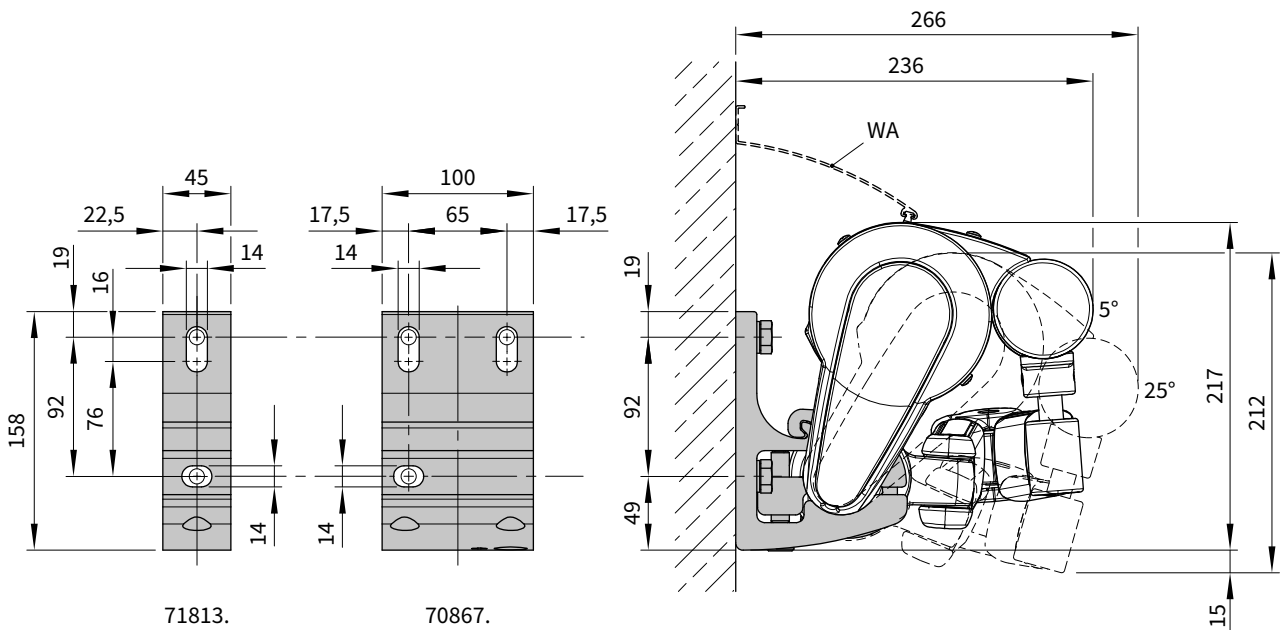

dimensions in mm

Face fixture with spreader plate A

Pull-out force [N=Newton] per upper fixing point according to EN 13561, wind resistance class 2

Compression-proof substrate
M [cm]

H [cm]	FB [N]									
150	230	263	296	329	362	395	428	462	495	406
200	384	437	490	543	596	650	703	756	809	685
250	-	627	705	782	860	938	1015	1093	1334	1162
300	-	-	957	1063	1170	1277	1581	1706	1831	1620
350	-	-	-	1423	1563	1948	2113	2278	2042	2196

Non Compression-proof substrate
M [cm]

H [cm]	FB [N]									
150	326	373	420	467	515	562	609	656	703	578
200	545	621	696	772	848	923	999	1074	1150	973
250	-	891	1001	1112	1222	1333	1443	1553	1896	1652
300	-	-	1359	1511	1662	1814	2247	2425	2602	2302
350	-	-	-	2022	2222	2768	3003	3237	2902	3121

HT BHT	2 100 mm		2 100 mm 1 45 mm	3 100 mm 1 45 mm
BP	2		2	3
DP	-		1	1
BM	16		18	26

HT BHT	2 100 mm		2 100 mm 1 45 mm	3 100 mm 1 45 mm
BP	2		2	3
DP	-		1	1
BM	16		18	26

BP	2		2	3
DP	-		1	1
BM	16		18	26

BP	2		2	3
DP	-		1	1
BM	16		18	26

The pull-out force refers to the vertical centre to centre measurement between the fixture points of **76 mm**.
In the case of spreader plates washers conforming to DIN 9021 must be used.

- M = awning width
- H = projection
- FB = pull-out force per fixing point
- HT | BHT = bracket quantity | width
- BP = no. of spreader plates
- DP = no. of spacer plates
- BM = no. of fixing points
- WA = wall sealing profile
- 75197. = stand-off strip for wall sealing profile

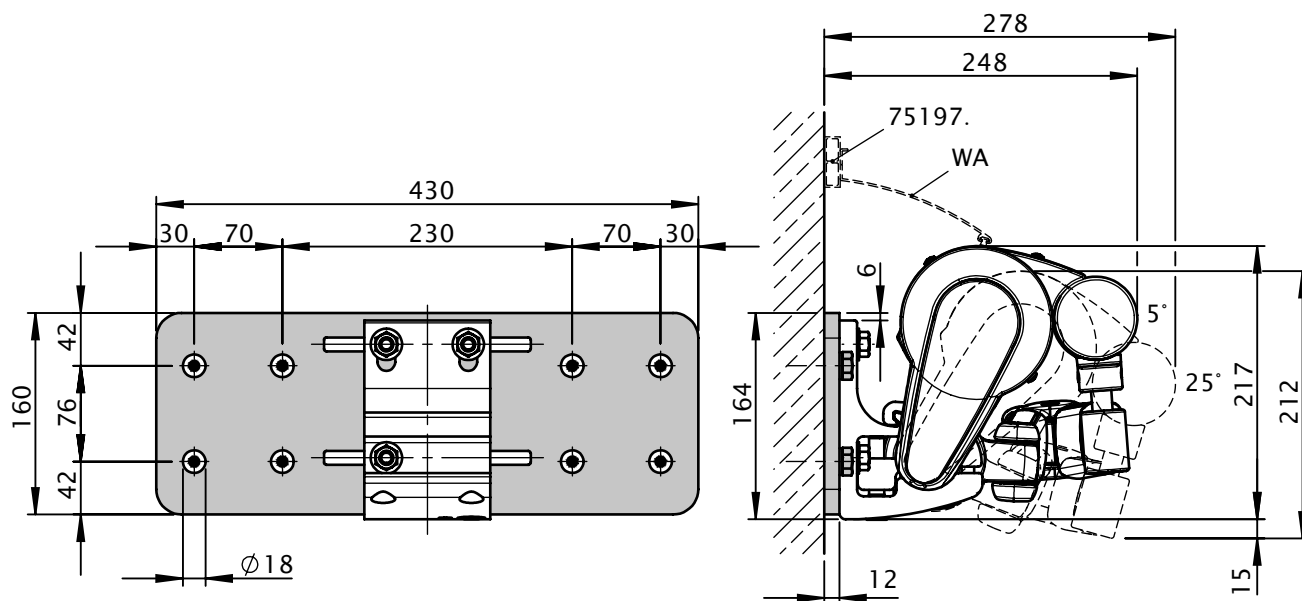

dimensions in mm

Face fixture with spreader plate B

Pull-out force [N=Newton] per upper fixing point according to EN 13561, wind resistance class 2

Compression-proof substrate
M [cm]

H [cm]	FB [N]									
150	136	155	175	195	214	234	254	273	293	241
200	227	259	290	322	353	384	416	447	479	405
250	-	371	417	463	692	555	601	647	789	688
300	-	-	566	629	692	755	936	1010	1084	959
350	-	-	-	842	925	1153	1250	1348	1209	1300

Non Compression-proof substrate
M [cm]

H [cm]	FB [N]									
150	142	162	183	203	223	244	264	285	305	251
200	237	270	302	335	368	401	434	467	499	423
250	-	387	435	483	531	579	627	675	823	717
300	-	-	590	656	722	788	976	1053	1130	1000
350	-	-	-	878	965	1202	1304	1406	1260	1355

HT BHT	2 100 mm		2 100 mm 1 45 mm	3 100 mm 1 45 mm
BP	2		2	3
DP	-		1	1
BM	8		10	14

HT BHT	2 100 mm		2 100 mm 1 45 mm	3 100 mm 1 45 mm
BP	2		2	3
DP	-		1	1
BM	8		10	14

HT BHT	2 100 mm		2 100 mm 1 45 mm	3 100 mm 1 45 mm
BP	2		2	3
DP	-		1	1
BM	8		10	14

HT BHT	2 100 mm		2 100 mm 1 45 mm	3 100 mm 1 45 mm
BP	2		2	3
DP	-		1	1
BM	8		10	14

The pull-out force refers to the vertical centre to centre measurement between the fixture points of **350 mm**.
In the case of spreader plates washers conforming to DIN 9021 must be used.

- M = awning width
- H = projection
- FB = pull-out force per fixing point
- HT | BHT = bracket quantity | width
- BP = no. of spreader plates
- DP = no. of spacer plates
- BM = no. of fixing points

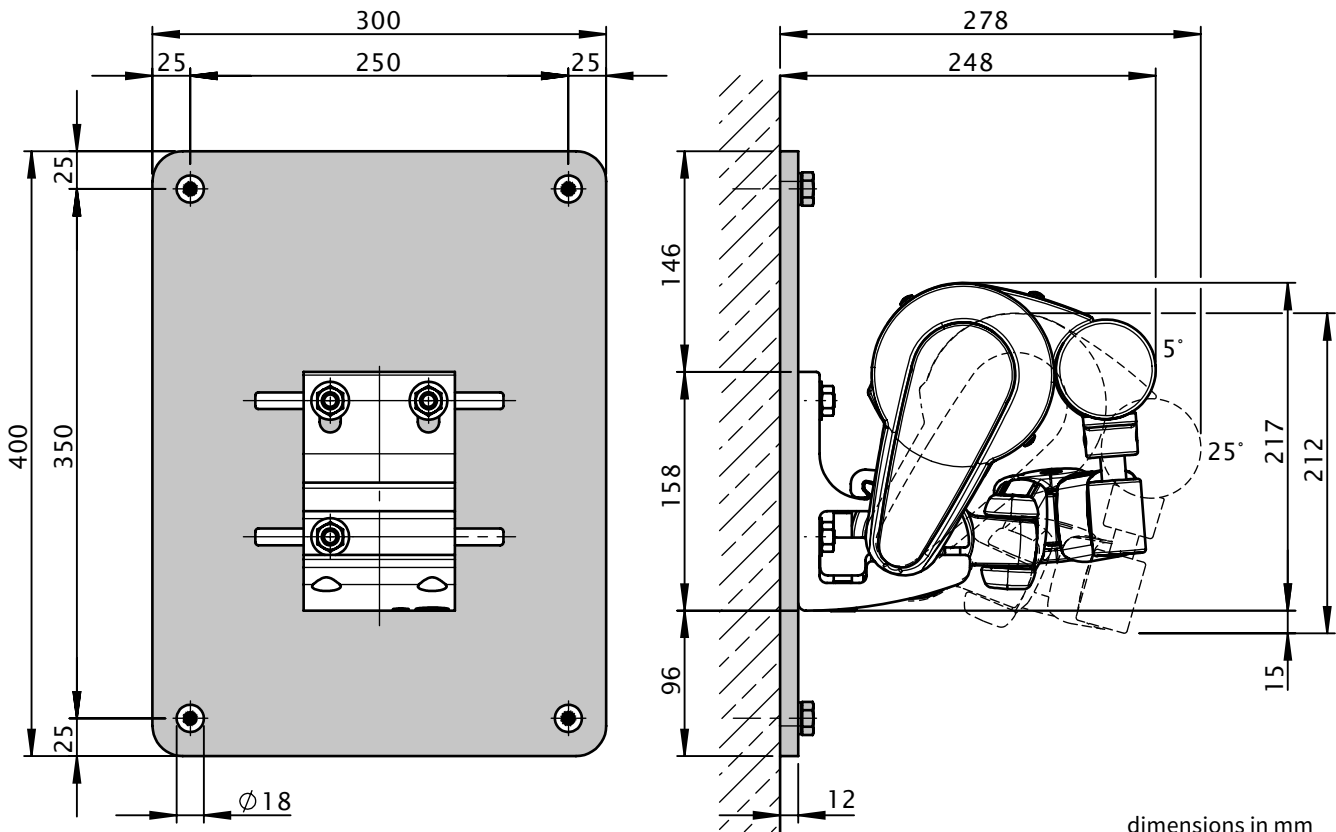

dimensions in mm

Face fixture with stand-off brackets

Pull-out force [N=Newton] per upper fixing point according to EN 13561, wind resistance class 2

Compression-proof substrate										Non Compression-proof substrate										
M [cm]										M [cm]										
H [cm]										FB [N]										
250	300	350	400	450	500	550	600	650	700	250	300	350	400	450	500	550	600	650	700	
150	479	547	615	683	751	820	888	956	1024	841	538	615	692	769	845	922	999	1076	1152	946
200	761	865	970	1074	1178	1283	1387	1492	1596	1350	856	973	1091	1208	1326	1443	1561	1678	1796	1519
250	-	1200	1347	1495	1643	1791	1938	2086	2551	2223	-	1350	1516	1682	1848	2014	2181	2347	2870	2500
300	-	-	1785	1983	2181	2379	2952	3185	3418	3023	-	-	2008	2231	2454	2677	3321	3583	3845	3401
350	-	-	-	2607	2863	3571	3873	4175	3743	4024	-	-	-	2932	3220	4017	4357	4697	4211	4527
HT BHT	2 100 mm				2 100 mm 1 45 mm			3 100 mm 1 45 mm			2 100 mm				2 100 mm 1 45 mm		3 100 mm 1 45 mm			
DH 77968.	2				2			3			2				2		3			
DH 77967.	-				1			1			-				1		1			
BM	8				12			16			8				12		16			

The pull-out force refers to the vertical centre to centre measurement between the fixture points of 120 mm. In the case of stand-off brackets a washer conforming to DIN 9021 must be used.

- M = awning width
- H = projection
- FB = pull-out force per fixing point
- HT | BHT = bracket quantity | width
- BM = no. of fixing points
- DH = no. of stand-off brackets
- 77967. = stand-off bracket for face fixture bracket assembly 71813.
- 77968. = stand-off bracket for face fixture bracket assembly 70867.

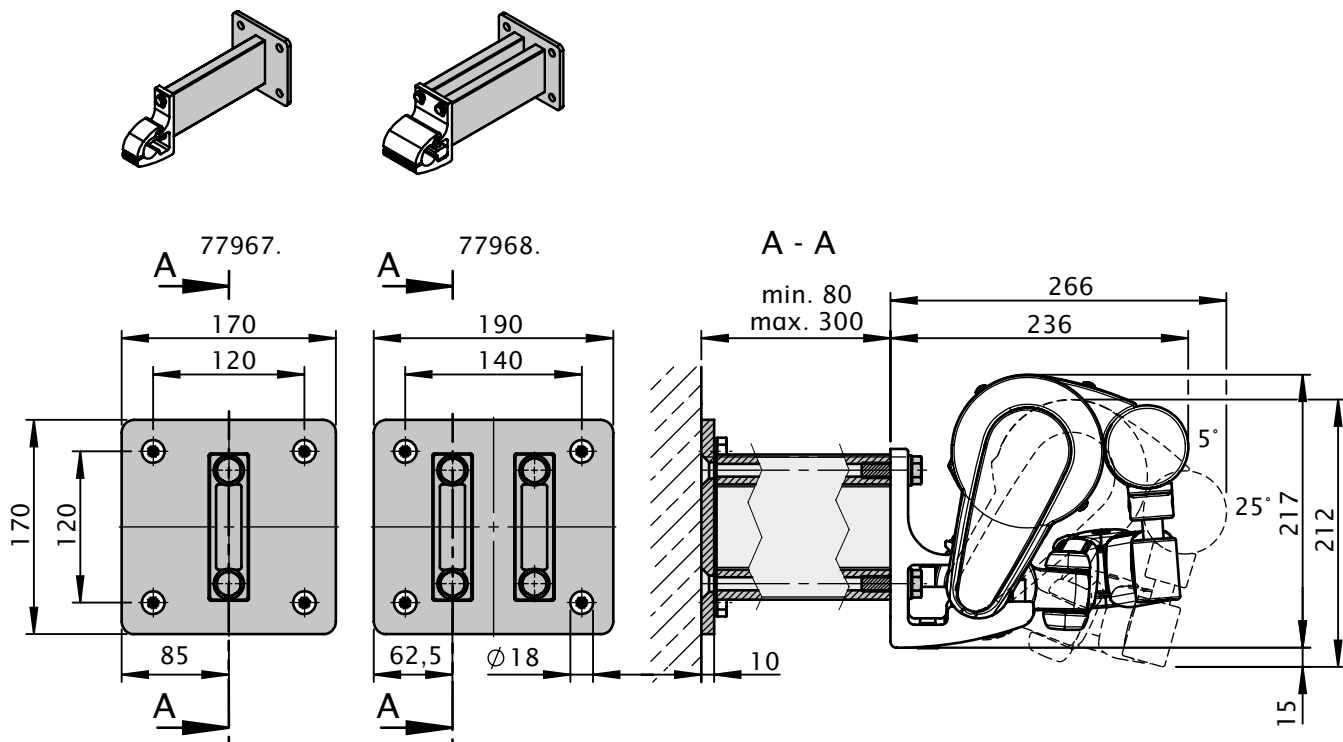

dimensions in mm

Top fixture

Pull-out force [N=Newton] per upper fixing point according to EN 13561, wind resistance class 2

Compression-proof substrate
M [cm]

Non Compression-proof substrate
M [cm]

H [cm]	Compression-proof substrate										Non Compression-proof substrate									
	FB [N]										FB [N]									
150	488	562	636	710	784	858	932	1006	1080	977	674	775	876	977	1078	1179	1280	1381	1482	1328
200	776	888	999	1110	1222	1333	1445	1556	1668	1541	1088	1243	1398	1552	1707	1862	2017	2171	2326	2138
250	-	1243	1400	1558	1715	1872	2029	2187	2648	2471	-	1754	1975	2195	2416	2637	2857	3078	3735	3475
300	-	-	1872	2083	2295	2506	3087	3333	3578	3371	-	-	2652	2951	3249	3548	4377	4725	5073	4769
350	-	-	-	2757	3031	3761	4082	4403	4228	4529	-	-	-	3919	4308	5352	5808	6263	6007	6435

HT BHT	Compression-proof		Non Compression-proof	
	2 90 mm	2 90 mm 1 45 mm	3 90 mm 1 45 mm	2 90 mm 1 45 mm

BM	Compression-proof			Non Compression-proof		
	8	10	14	8	10	14

The pull-out force refers to the vertical centre to centre measurement between the fixture points of **80 mm**. If the awning is fitted with two brackets per folding arm the pull-out force may be halved.

Place the brackets immediately to the left and right of the arm bearer.

- M = awning width
- H = projection
- FB = pull-out force per fixing point
- HT | BHT = bracket quantity | width
- BM = no. of fixing points
- 70868. = top fixture bracket assembly 90 mm
- 71818. = top fixture bracket assembly 45 mm

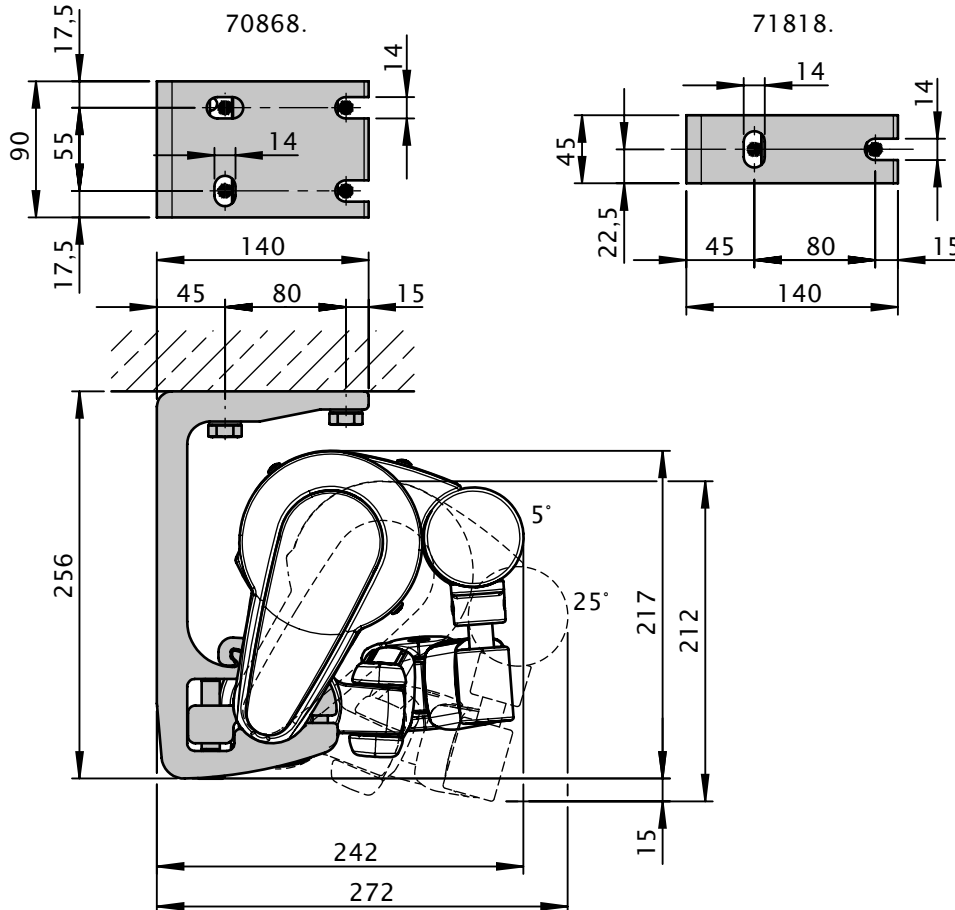

dimensions in mm

Eaves fixture

Torque [Nm = Newton metres] for the fixture bracket next to the arm, shear force [N = Newton] per fixing point according to EN 13561, wind resistance class 2

		Torque M [cm]										Shear force M [cm]									
		250	300	350	400	450	500	550	600	650	700	250	300	350	400	450	500	550	600	650	700
H [cm]	Md [Nm]											FS [N]									
150	98	112	126	140	154	169	183	197	211	185	1213	1395	1577	1759	1942	2124	2306	2488	2671	2401	
200	164	187	210	232	255	278	301	323	346	314	1949	2226	2504	2782	3060	3338	3616	3894	4172	3841	
250	-	269	302	335	369	402	435	468	502	528	-	3135	3530	3925	4320	4715	5110	5505	6676	6217	
300	-	-	410	456	502	548	678	732	786	735	-	-	4735	5268	5802	6335	7812	8433	9054	8517	
350	-	-	-	611	671	836	907	978	935	1002	-	-	-	6990	7684	9543	10356	11168	10715	11478	
HT	2			3			4				2			3			4				
BM	8			12			16				8			12			16				

The shear force is calculated on the basis of 2 fixing points per bracket, because – depending on the roof pitch – it cannot be guaranteed that 4 fixing points per bracket can be used.

- M = awning width
- H = projection
- Md = torque value for the bracket in the immediate vicinity of the arm
- HT = no. of brackets
- FS = shear force
- BM = no. of fixing points

with eaves fixture bracket 150 mm

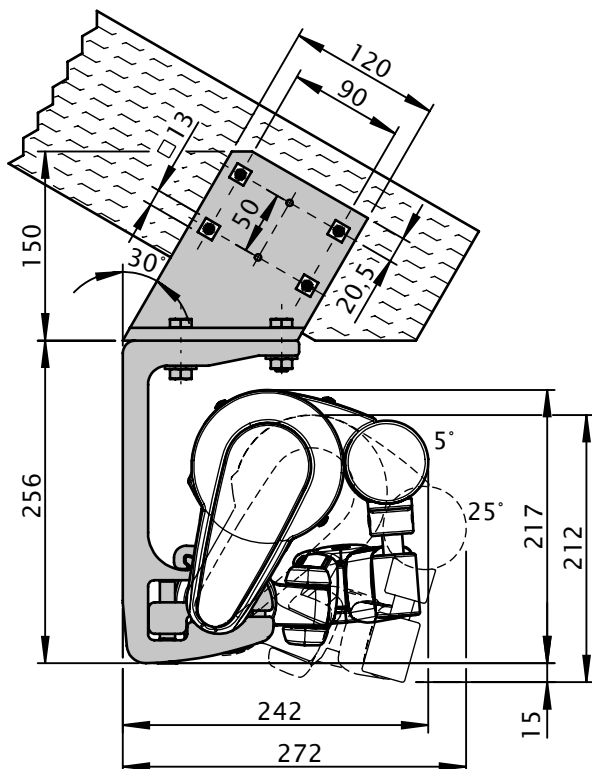

with eaves fixture bracket 270 mm

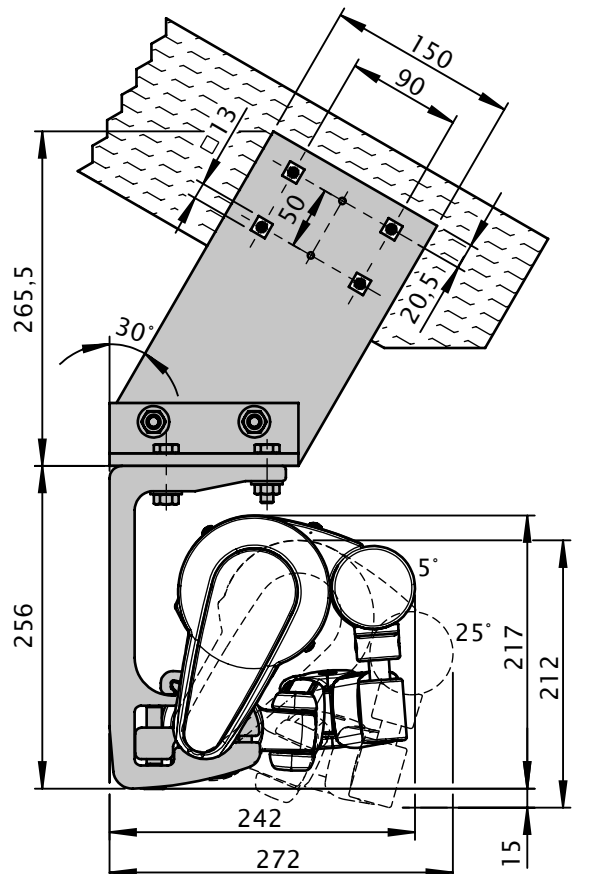

dimensions in mm

01
02
03
04
05
06
07
08
09
10
11
12
13
14
15
16
17
18
19
20
21
22
23

Eaves fixture with additional spreader / backing plate

Torque [Nm = Newton metres] for the fixture bracket in the immediate vicinity of the arm, shear force [N = Newton] per fixing point according to EN 13561, wind resistance class 2

H [cm]	Torque M [cm]										Shear force M [cm]									
	250	300	350	400	450	500	550	600	650	700	250	300	350	400	450	500	550	600	650	700
	Md [Nm]										FS [N]									
150	98	112	126	140	154	169	183	197	211	185	614	710	806	902	997	1093	1189	1285	1380	1273
200	164	187	210	232	255	278	301	323	346	314	946	1084	1223	1362	1501	1640	1778	1917	2056	1921
250	-	269	302	335	369	402	435	468	572	528	-	1493	1685	1876	2068	2259	2451	2642	3183	2990
300	-	-	410	456	502	548	678	732	786	735	-	-	2227	2481	2735	2988	3667	3960	4253	4025
350	-	-	-	611	671	836	907	978	935	1002	-	-	-	3256	3581	4432	4811	5191	5001	5358
HT	2				3			4			2				3			4		
BM	4				6			8			4				6			8		

By using the additional flat fixture plate, the shear force is reduced in comparison with conventional eaves fixture.

- M = awning width
- H = projection
- Md = torque value for the bracket in the immediate vicinity of the arm
- HT = no. of brackets
- FS = shear force
- BM = no. of fixing points

with eaves fixture bracket 150 mm

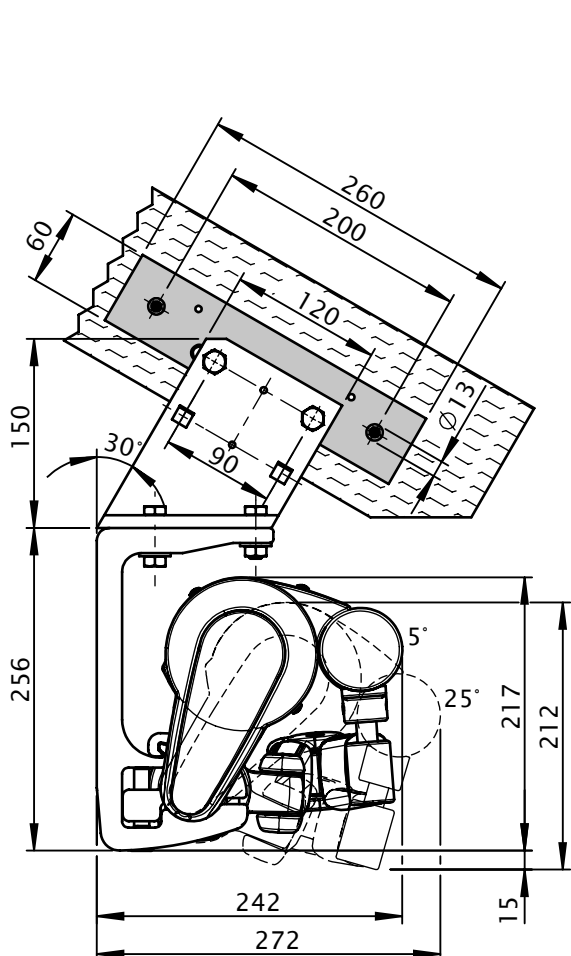

with eaves fixture bracket 270 mm

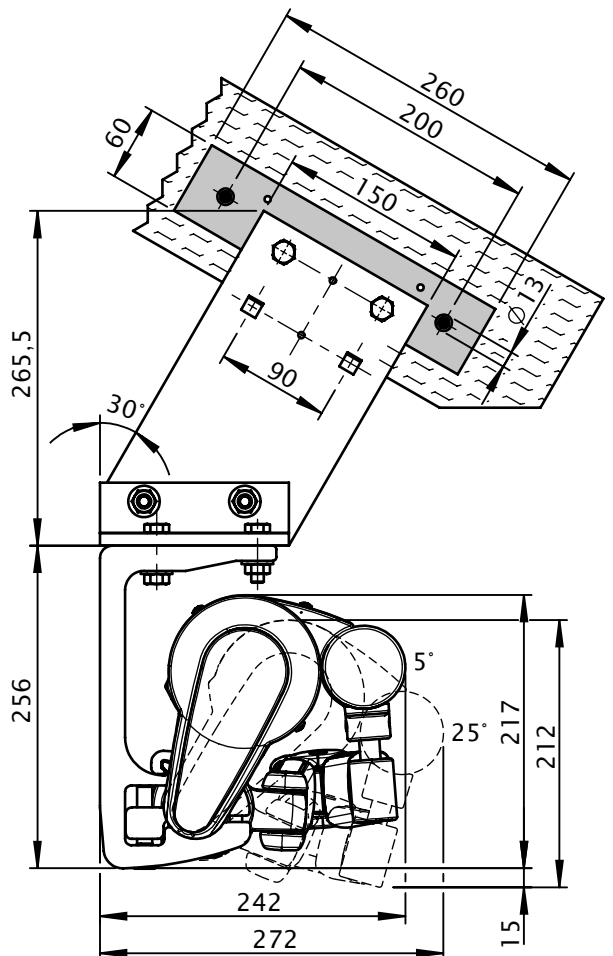

dimensions in mm

Installation using the adjustable eaves fixture bracket

Pull-out force [N=Newton] per upper fixing point according to EN 13561, wind resistance class 2

Compression-proof substrate											Non Compression-proof substrate											
M [cm]											M [cm]											
H [cm]											FB [N]											
250	300	350	400	450	500	550	600	650	700		250	300	350	400	450	500	550	600	650	700		
150	800	923	1045	1168	1291	1413	1536	1658	1781	1623	824	950	1076	1202	1329	1455	1581	1707	1833	1668		
200	1257	1439	1621	1803	1985	2167	2349	2531	2713	2517	1297	1485	1672	1860	2048	2235	2423	2610	2798	2594		
250	-	2003	2257	2512	2767	3021	3276	3531	4267	3992	-	2069	2332	2595	2858	3120	3383	3646	4408	4122		
300	-	-	3005	3346	3687	4027	4953	5348	5743	5419	-	-	3106	3458	3810	4162	5120	5528	5937	5600		
350	-	-	-	4414	4855	6018	6532	7046	6774	7257	-	-	-	4565	5020	6224	6755	7287	7004	7504		
HT BHT	2 90 mm				2 90 mm			3 90 mm				2 90 mm				2 90 mm			3 90 mm			
					1 45 mm			1 45 mm								1 45 mm			1 45 mm			
BM	8				10			14				8				10			14			

The pull-out force refers to the measurement from the front to the rear fixture points of 140 mm. Washers conforming to DIN 9021 must be used.

- M = awning width
- H = projection
- FB = pull-out force per fixing point
- HT | BHT = bracket quantity | width
- BM = no. of fixing points

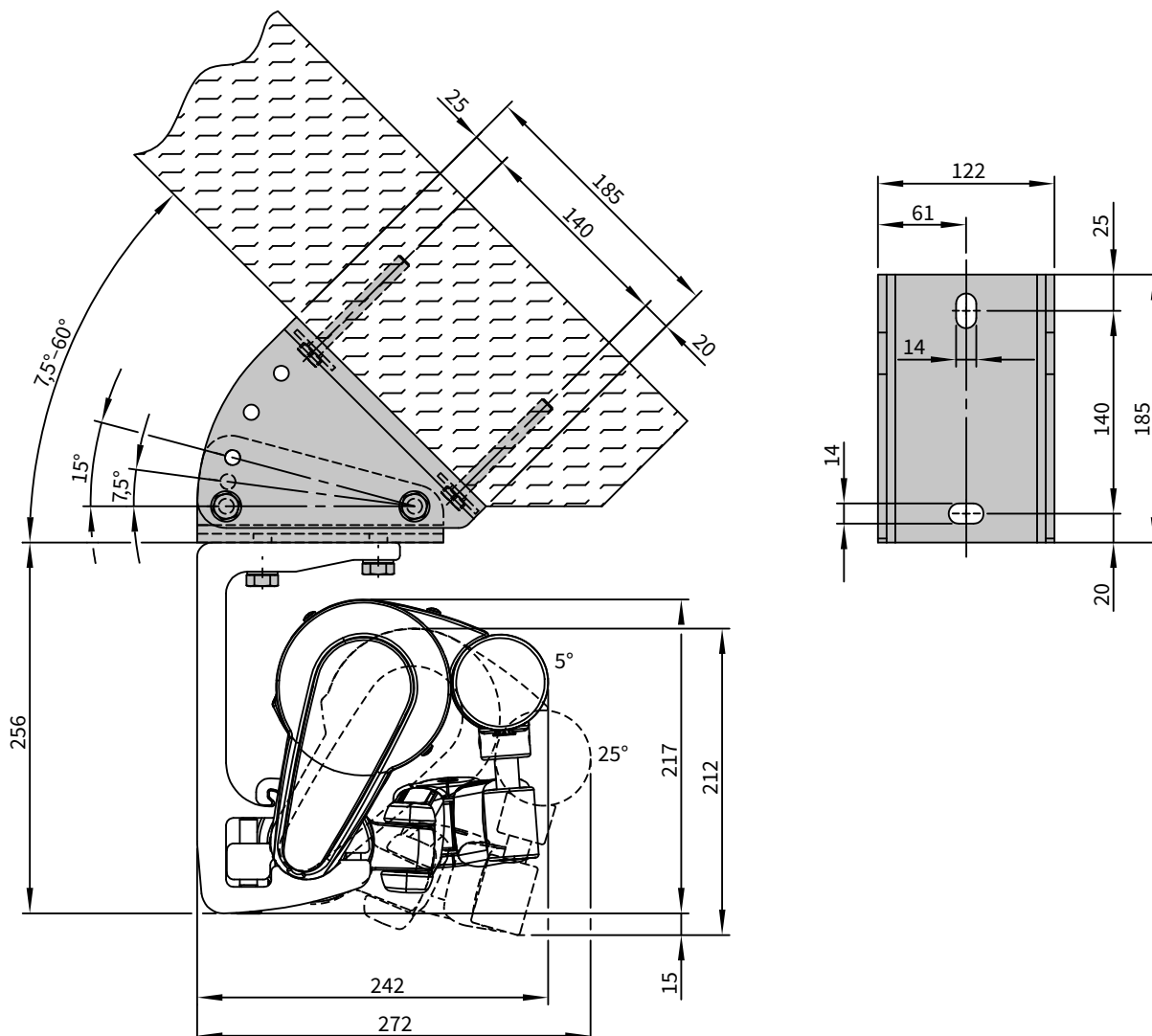

dimensions in mm

Face fixture with manual operation

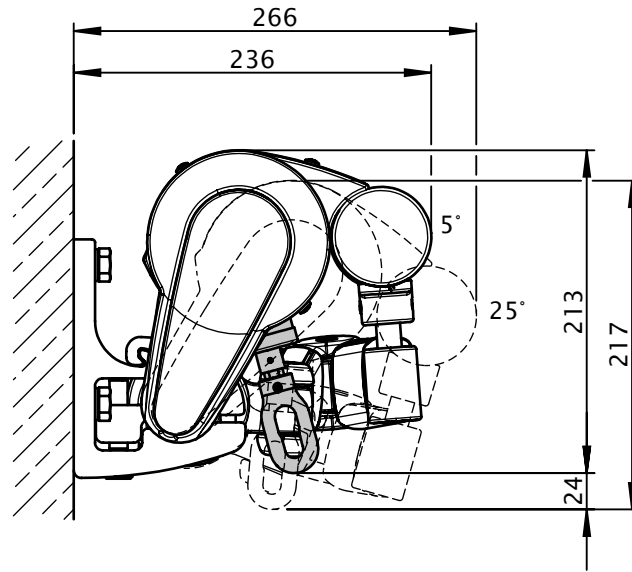

dimensions in mm

Face fixture with wall sealing profile

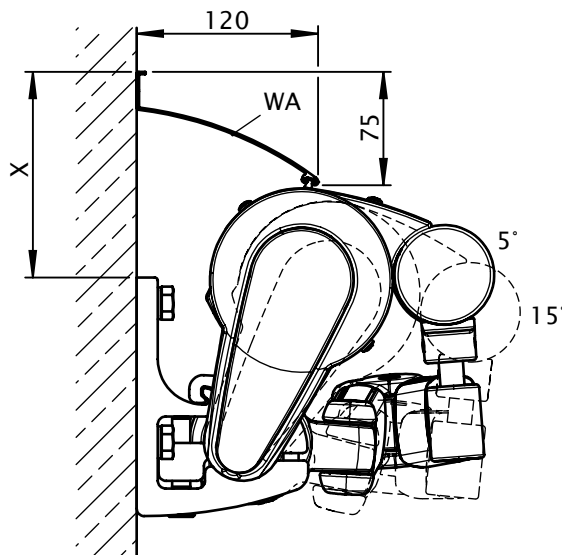

awning pitch	X
5°	136 mm
10°	132 mm
15°	127 mm
20°	-
25°	-

WA = wall sealing profile
 X = distance upper edge face fixture bracket to upper edge wall sealing profile

dimensions in mm

Cable exit position in motor-driven units

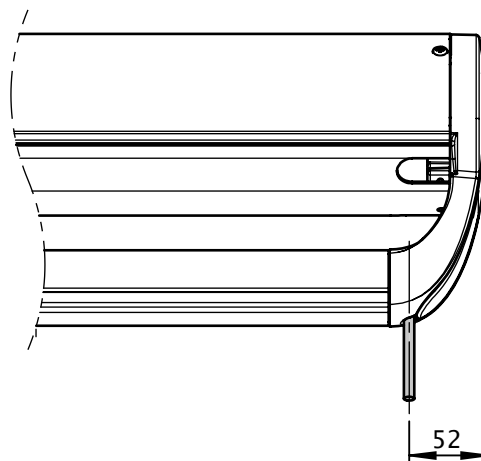
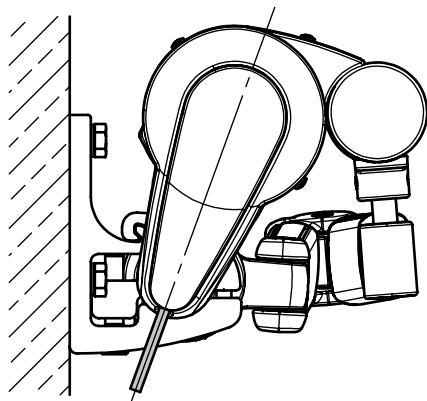

dimensions in mm

- 01
- 02
- 03
- 04
- 05
- 06
- 07
- 08**
- 09
- 10
- 11
- 12
- 13
- 14
- 15
- 16
- 17
- 18
- 19
- 20
- 21
- 22
- 23

Bracket fixture range for awnings with 2 folding arms

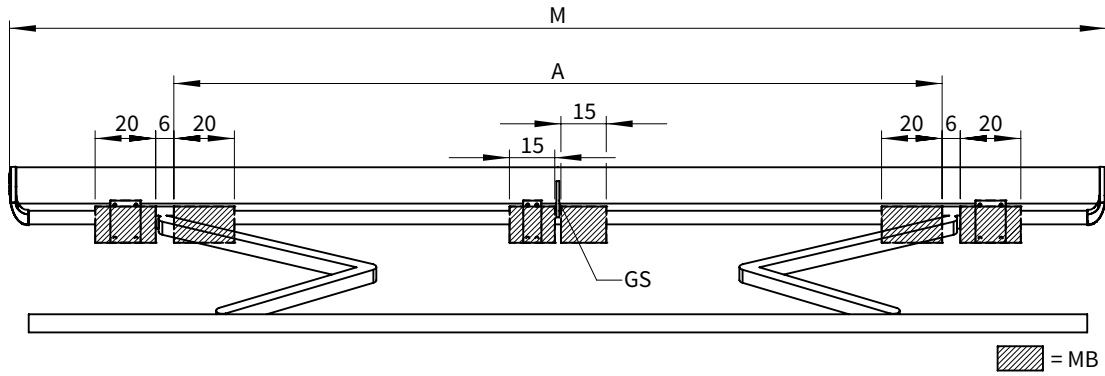

dimensions in cm

M [cm]	SB →	250	300	350	400	450	500	550	600	650
	ZB →	180–250	180–250	180–250	180–250	180–250	180–250	180–250	180–250	601–650

H [cm] ↓	A [cm]								
150	154*	210	240	280	320	390	425	460	500
200	204**	210*	240	280	320	390	425	460	500
250	-	254**	260*	280	320	390	425	460	500
300	-	-	304**	310*	320	390	425	460	500
350	-	-	-	354**	360*	390	425	460	-

dimensions in cm

W	BHT ↓	HT ↓	
	45 mm	-	1
100 mm	2	2	

DE	45 mm	-	1
	90 mm	2	2

DA	90 mm	2	3
----	-------	---	---

If the brackets cannot be positioned in accordance with this table, make sure the actual measurements are noted on the order form!

- * = Coupled units are only available with a junction roller in the standard widths, in the case of other widths please ask us.
- ** = Please note the minimum widths! Dimension A is only valid for standard arms! Dimension A is 13 cm smaller in the case of bespoke arms; in the case of small awnings the brackets can only be fitted inside the arms, i.e. the position denoted by measurement A.

- A = arm position
- BHT = bracket width
- DA = eaves fixture
- DE = top fixture
- GS = cassette support bracket
- H = projection
- HT = no. of brackets
- M = awning width
- MB = bracket fixture range
- SB = standard width
- W = face fixture
- ZB = intermediate width

Bracket fixture range for awnings with 3 folding arms

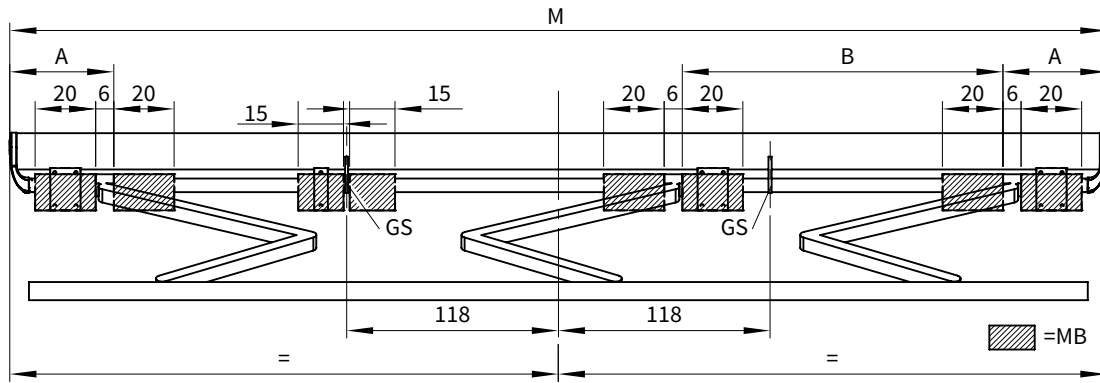

dimensions in cm

M [cm]	SB →	650	700		
	ZB →	618–650	651–674	675–689	690–700

H [cm] ↓	A [cm] ↓	B [cm] ↓	A [cm] ↓	B [cm] ↓	A [cm] ↓	B [cm] ↓	A [cm] ↓	B [cm] ↓	KM [cm] ↓
150	-	-	55	235	55	245	55	245	418
200	-	-	55	225	55	235	55	235	468
250	-	-	55	215	55	225	55	225	518
300	-	-	45	210	55	215	55	215	568
350	13*	215*	23*	215*	31	225	38	225	618

dimensions in cm

W	BHT ↓	HT ↓
	45 mm	1
	100 mm	3

DE	45 mm	1
	90 mm	3

DA	90 mm	4
----	-------	---

If the brackets cannot be positioned in accordance with this table, make sure the actual measurements are noted on the order form!

* = Dimension A is valid only for standard widths, coupled units not available with junction roller.

A = arm position

B = arm position

BHT = bracket width

DA = eaves fixture

DE = top fixture

GS = cassette support bracket

H = projection

HT = no. of brackets

KM = minimum awning width

LR = a rolltex bearing with accompanying bracket is always placed under a central seam (depends on the awning size)

M = awning width

MB = bracket fixture range

SB = standard width

W = face fixture

ZB = intermediate width

Installation dimensions at varying awning pitches

Top fixture

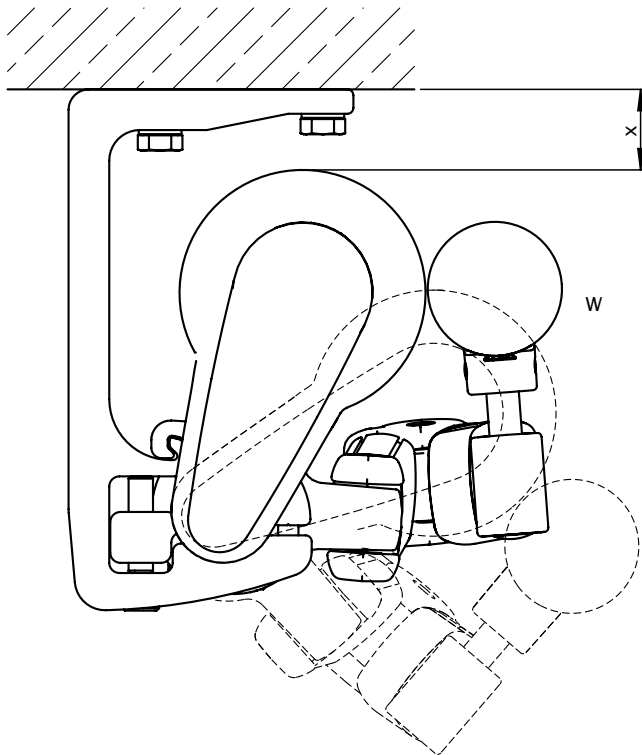

pitch (W)	approx. height in mm (X)
5°	40
10°	44
15°	48
20°	54
25°	60
30°	66
35°	74
40°	82
45°	90
50°	99

Face fixture

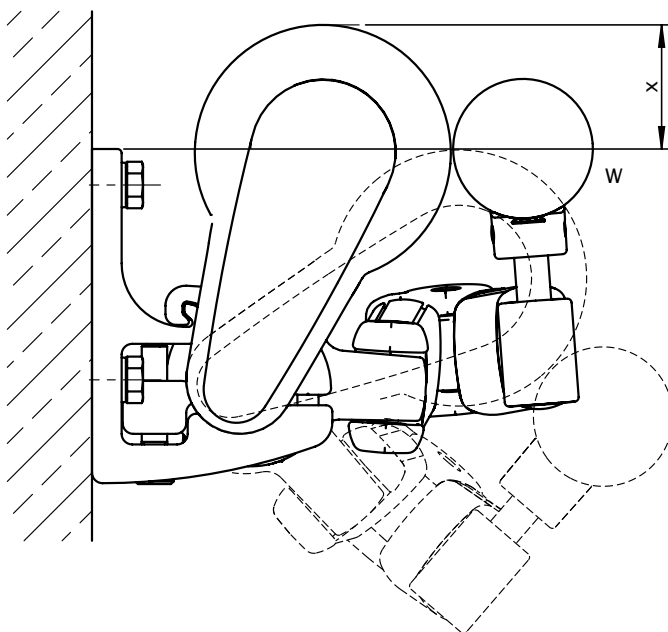

pitch (W)	approx. height in mm (X)
5°	59
10°	55
15°	50
20°	45
25°	39
30°	32
35°	25
40°	17
45°	8
50°	0